

Series 70 Mixers

TOP ENTRY MIXERS



A World Leader In Industrial Mixing Since 1923. Lightnin has over 85 years of unrivaled experience in industrial mixing technology, process knowledge, and technological innovation. Lightnin enjoys a global reputation for durable, long-lasting mixers, agitators, aerators, and flocculators for fluid process systems. We offer a full spectrum of impeller designs for diverse applications. In addition, we offer a worldwide service network, mixer repair, gearbox repair, and replacement parts programs. Look to Lightnin for knowledge, technology and service excellence.

Based in Charlotte, North Carolina, SPX Corporation (NYSE: SPW) is a global Fortune 500 multi-industry manufacturing leader. The company's highly-specialized, engineered products and technologies serve customers in three primary strategic growth markets: infrastructure, process solutions, and diagnostic systems. Many of SPX's innovative solutions are playing a role in helping to meet rising global demand, particularly in emerging markets, for electricity, processed foods and beverages and vehicle services. The company's products include thermal heat transfer equipment for power plants; power transformers for utility companies; process equipment for the food & beverage industry; and diagnostic tools and equipment for the vehicle service industry. For more information, please visit www.spx.com.

The Most Experienced Mixer Technology In The World - Lightnin Series 70

Over 30,000 Lightnin Series 70 mixers have been placed in service since we began manufacturing them in 1970. The same design technology is used in Lightnin Series 90 Mixers, as well as in RMX and most CMX replacement drives for older mixers. The gear train is the same as in our Series 80 Mixers. That makes the Series 70 mechanical design technology the most specified, most used, and most proven mixer technology in the world. It's our standard and the standard of the industry.

PRODUCT BENEFITS AND FEATURES

- **1 - 200 HP:** Lightnin Series 70 Mixers cover the range from 1 - 200 hp. They are available in both double and triple reduction gearing, and come in a full range of standard AGMA speeds from 280 down to 16.5 rpm.
- **Full Spectrum of Impellers:** Series 70 Mixers offer a full choice of impellers in order to optimize your process results. Included are the high-flow A310, as well as other high performance and more traditional impellers, so we can match shear and flow to your process requirements exactly.
- **Guaranteed Performance:** Together we decide what mixing should do to optimize your process. Then we recommend the impeller, mixer speed, shaft length and other specifications. And we guarantee performance results.
- **Tested 100%:** We employ a non-load test run on every Series 70 and Series 80 before they are shipped.
- **Series 70 Integral Stuffing Boxes:** The standard Series 70 stuffing box combines a split lantern ring, split packing gland and seven rings of packing with separators. The lantern ring distributes lubricant for better sealing performance. All fits are dowl or rabbet to assure alignment. You'll find this Lightnin design makes for easy repacking.
- **Variable Speed Drives:** The Lightnin Vari-Mix is offered on Series 70 mixers where speed variations are needed. It is a compact, enclosed, in-motion control unit, created especially for mixer service.
- **Open Tank Models:** Series 70 models for open tanks require minimum headroom to simplify installation.

THEORY OF OPERATION:

Mechanical Seals

The replaceable cartridge design, a Lightnin original, is standard on Series 70 units. Light in weight. Easy to replace. No other design offers so much convenience. Integral stuffing box and open tank designs also available.

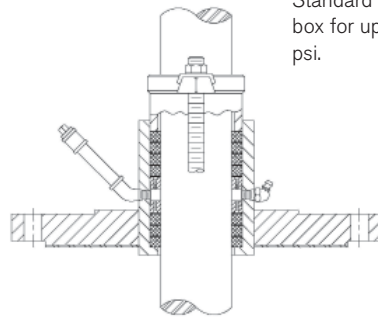

Standard stuffing box for up to 150 psi.

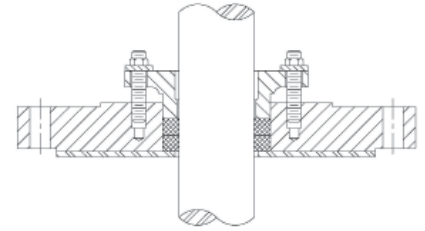

Low pressure stuffing box for up to 25 psi.

Positive Direct Drive

Mixer shaft slides directly into the quill, where it is rigidly coupled by a key and keyway. This design is the veteran of millions of hours of mixing.

Coupling Guards

Coupling guards meet OSHA standards and protect people from moving parts.

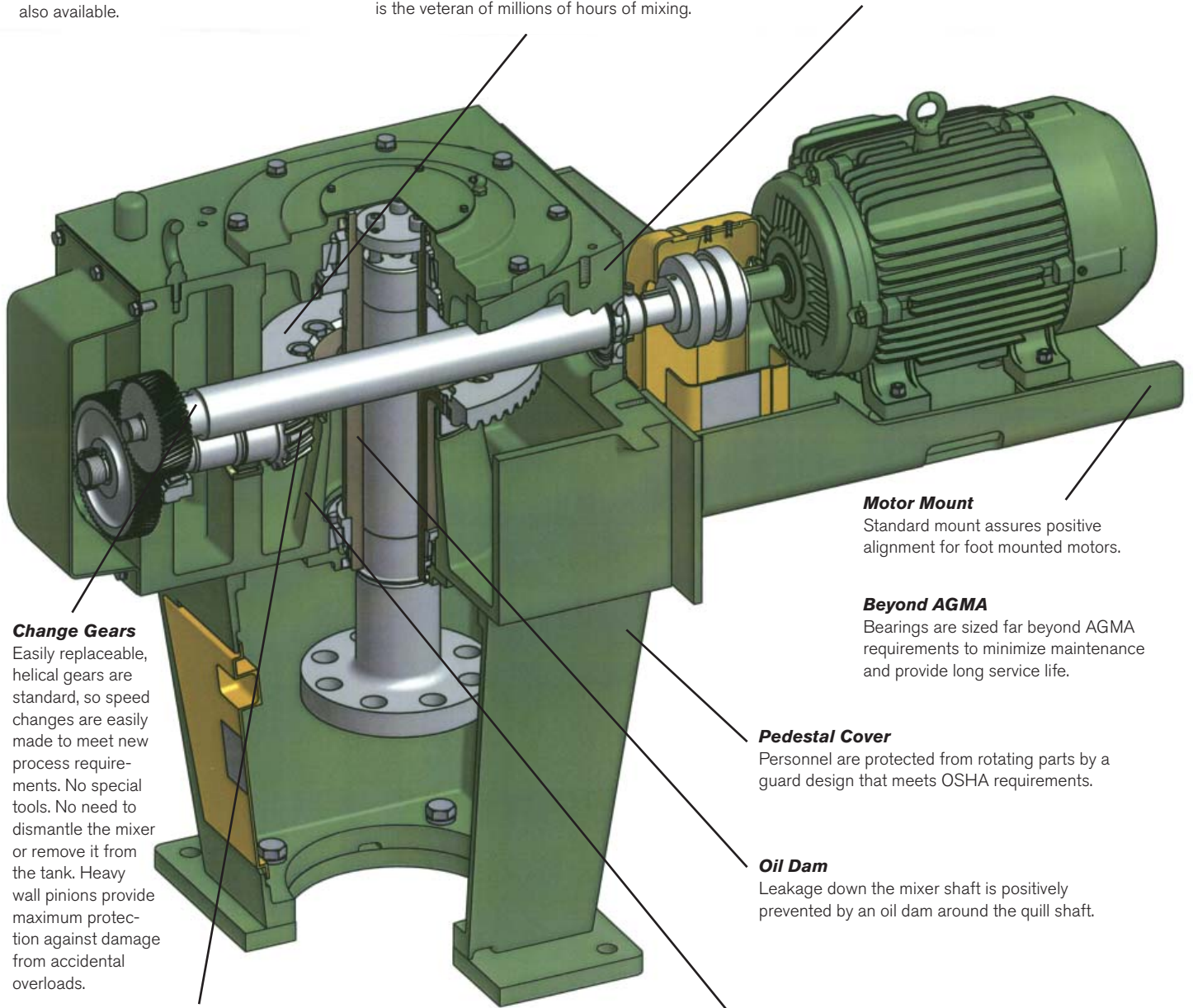

Motor Mount

Standard mount assures positive alignment for foot mounted motors.

Beyond AGMA

Bearings are sized far beyond AGMA requirements to minimize maintenance and provide long service life.

Pedestal Cover

Personnel are protected from rotating parts by a guard design that meets OSHA requirements.

Oil Dam

Leakage down the mixer shaft is positively prevented by an oil dam around the quill shaft.

Spiral Bevel Gears

High-efficiency spiral bevel gear and pinion are quiet running. They are precision generated, match lapped, individually mounted and micrometer checked to make sure.

Splash Lubrication

Rotating gears dip into the oil sump and assure a constant flow of oil to all surfaces. No need for pumps or piping.

Change Gears

Easily replaceable, helical gears are standard, so speed changes are easily made to meet new process requirements. No special tools. No need to dismantle the mixer or remove it from the tank. Heavy wall pinions provide maximum protection against damage from accidental overloads.



EXCLUSIVE MECHANICAL SEAL DESIGN

Series 70 mechanical seals incorporate all the many significant improvements originated by Lightnin over the years.

Each is tested 100% before shipment. No on-the-tank alignment, adjustment, or run-in is needed. Seals are self-setting by means of springs that position the faces for equal compression.

Seal and bearing lubricants are completely separate. Each has its own inlet and outlet. Ordinary tap water can be circulated around the seal housing for cooling.

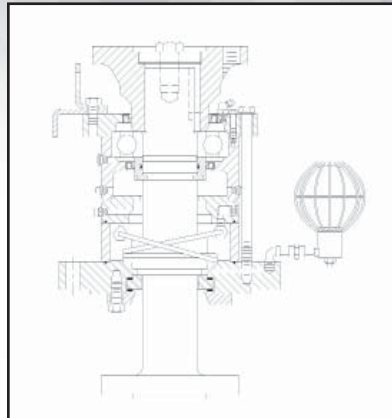

Single Seal With Constant Level Lubricator

Bulb sight glass shows level and serves as a reservoir to automatically feed lube to the seal.

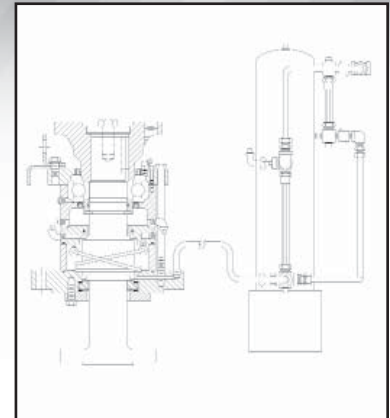

Double Seal With Dead End Lubricator

A trouble free unit with no moving parts. This lubricator seal provides constant pressure for the seal lubricant. It also provides a standby reservoir, so your mixer can continue operating while main reservoir is refilled.

Global locations

USA

SPX GLOBAL HEADQUARTERS

13515 Ballantyne Corporate Place
Charlotte, NC 28277
United States of America
+1 704 752 4400

APAC

SPX ASIA PACIFIC

2F, Treasury Building
1568 Hua Shan Road
Shanghai 20000523
Peoples Republic of China
+86 21 2208 5888

EMEA

SPX EUROPE

Ocean House
Towers Business Park
Wilmslow Road
Manchester, M20 2LY England
+44 (0) 161 2491170

SPX FLOW TECHNOLOGY

135 Mt. Read Blvd.
Rochester, NY 14611
P: (888) 649-2378 (MIX-BEST), US and Canada) or +1 (585) 436-5550
F: (585) 436-5589
E: lightnin@spx.com ▪ www.lightninmixers.com

SPX reserves the right to incorporate our latest design and material changes without notice or obligation.

Design features, materials of construction and dimensional data, as described in this bulletin, are provided for your information only and should not be relied upon unless confirmed in writing. Please contact your local sales representative for product availability in your region. For more information visit www.spx.com.

The green ">" is a trademark of SPX Corporation, Inc.