

CORROSION RESISTANCE AND HEAT TRANSFER



Heat Exchangers and
Components in Graphite
and Silicon Carbide



GRAPHITE AND SILICON CARBIDE MATERIAL AND DESIGN

Indian office
GAB Neumann c/o MAS Sealing Systems (P.) Ltd., Mumbai,
T 022 - 2850 1850 /4005 1679

SILICON CARBIDE AND GRAPHITE HEAT EXCHANGERS APPLICATIONS

Agrochemicals, Active Pharmaceutical Ingredients, Flavors, Fine Chemicals, Steel Copper Pickling, Automotive Batteries, Advanced Polymers



GRAPHITE AND SILICON CARBIDE THERMAL CONDUCTIVITY

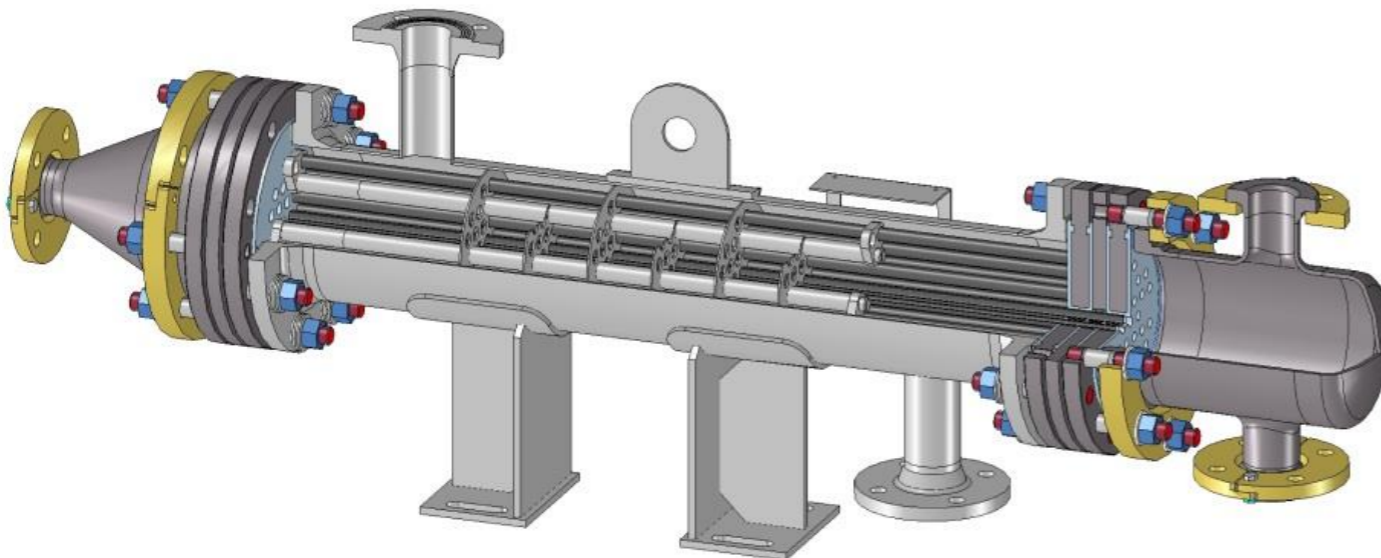
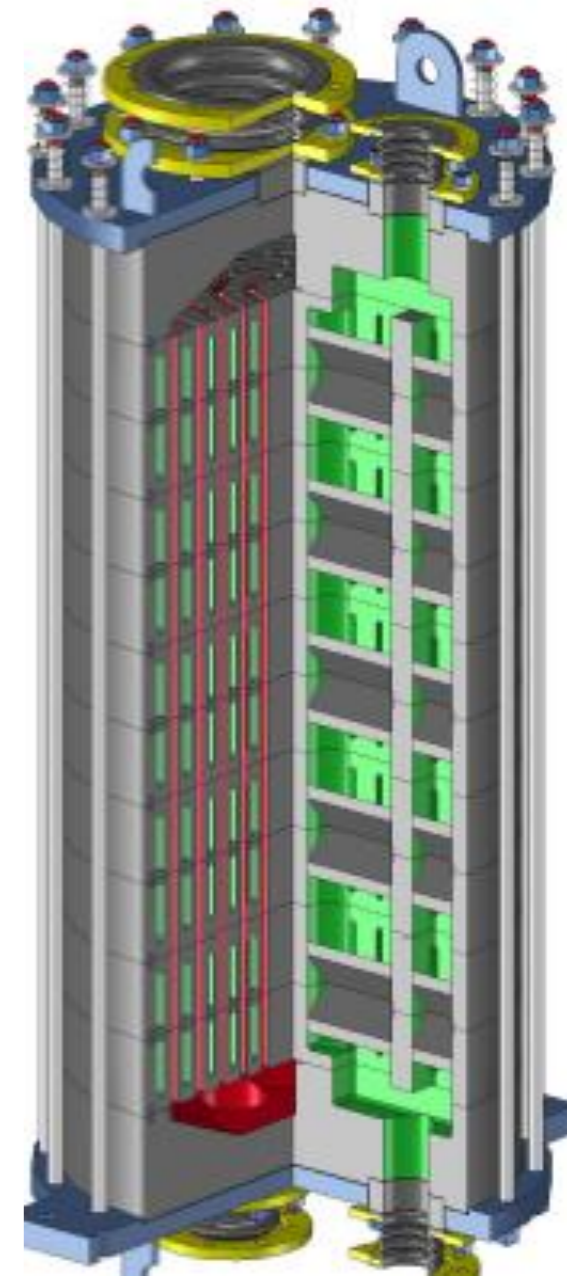
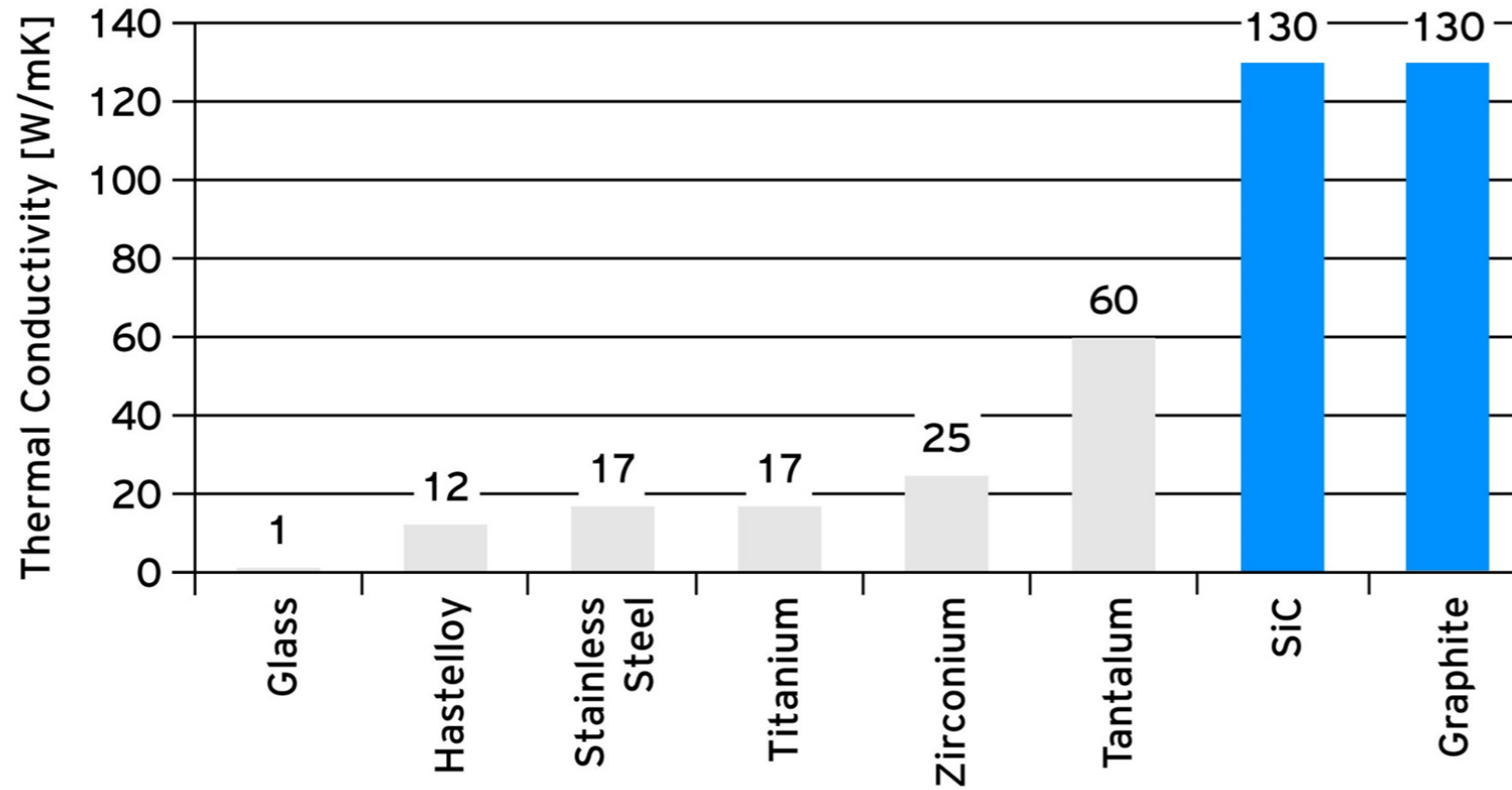

SYNTHETIC RESIN IMPREGNATED GRAPHITE PROPERTIES

		GAB Neumann		
		GPX1	GPX1T	GPX2
Density	g/cm ³	1,9±0,02	1,9±0,02	1,9±0,02
Max. grain size	mm	0,8	0,8	0,8
Resin content ¹⁾	%	≤22	≤22	≤15
Permeability	cm ² /s	10 ⁻⁶	10 ⁻⁶	10 ⁻⁶
Tensile strength (at 20°C)	N/mm ²	≥18	≥18	≥20
Flexural strength (at 20°C)	N/mm ²	≥32	≥32	≥35
Compressive strength (at 20°C)	N/mm ²	60-80	60-80	60-80
Identification according AD 2000 Merkblatt		G18-0-180 ²⁾	G18-0-200 ²⁾	G20-0-200 ²⁾
GXX-...-... (tensile strength at 20°C)	N/mm ²	18	18	20
G...-XX-... (drop in strength per +10K)	‰	0	0	0
G...-...-XX (max. admissible temperature)	°C	180	200	200

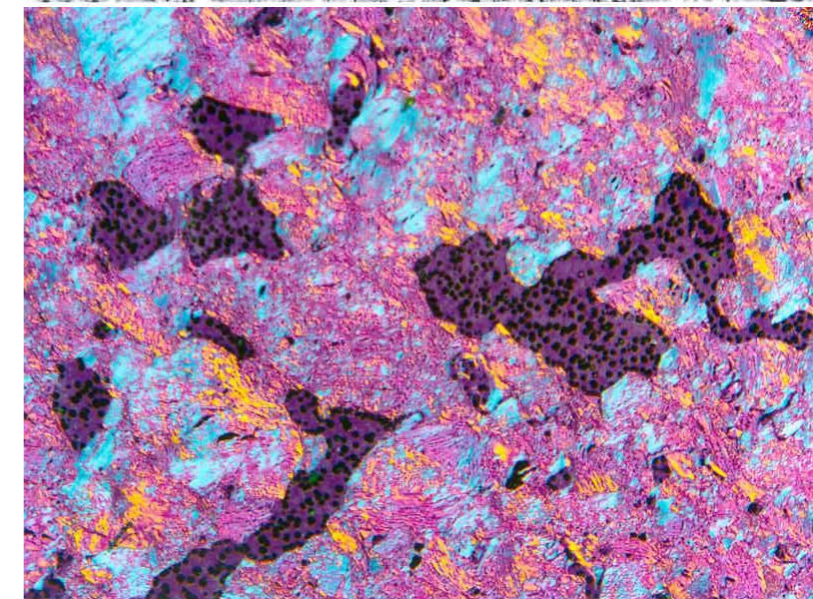

SYNTHETIC RESIN IMPREGNATED GRAPHITE HEAT EXCHANGERS ANNULAR GROOVE DESIGN PRINCIPLE

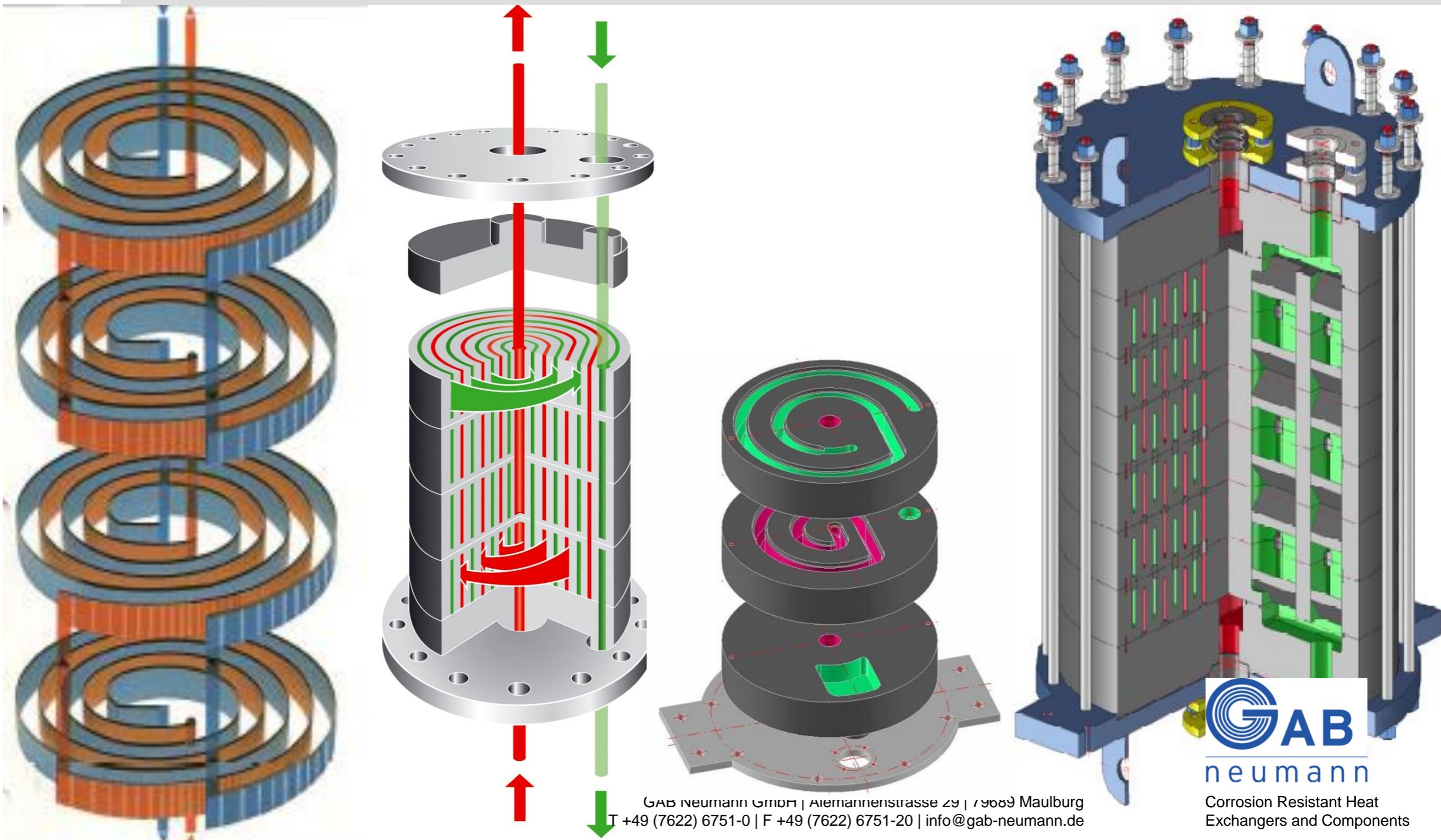

SYNTHETIC RESIN IMPREGNATED GRAPHITE HEAT EXCHANGERS ANNULAR GROOVE TYPES



*Annular-groove
condenser*

*for vertical or horizontal
installation
GMP design optionally*

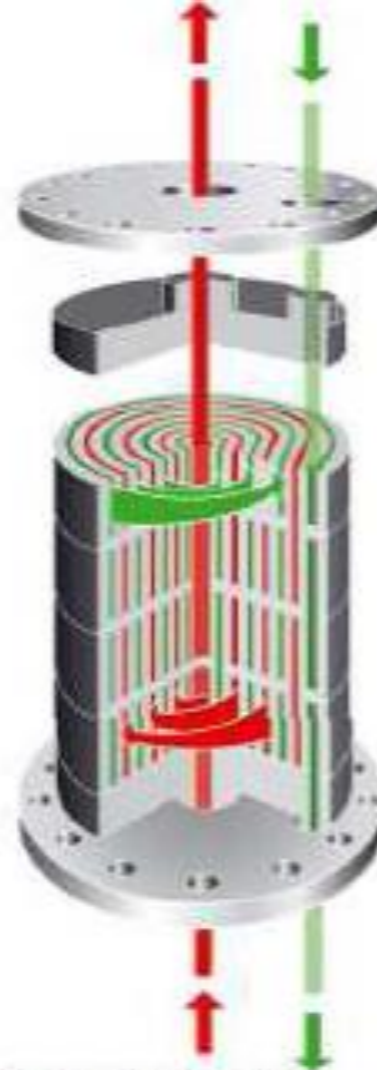

*Annular-groove
heat exchanger*

*high performance due to
optimal flow cross section
and real counterflow*



*Heat exchanger
GN type*

*with large flow cross-
section on process side,
e.g. as vent condenser or
behind dry vacuum pumps*

SYNTHETIC RESIN IMPREGNATED GRAPHITE HEAT EXCHANGERS ANNULAR GROOVE MANUFACTURING

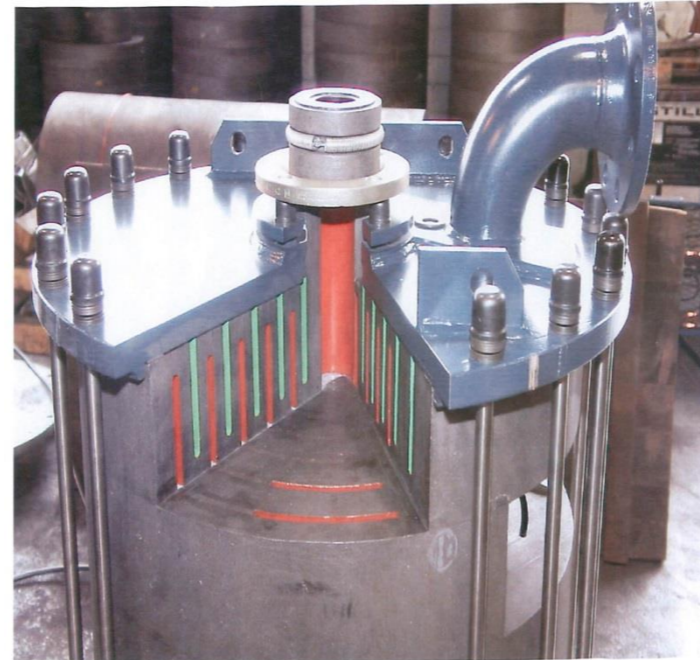

SYNTHETIC RESIN IMPREGNATED GRAPHITE HEAT EXCHANGERS ANNULAR GROOVE DESIGN BENEFITS

Annular-groove design

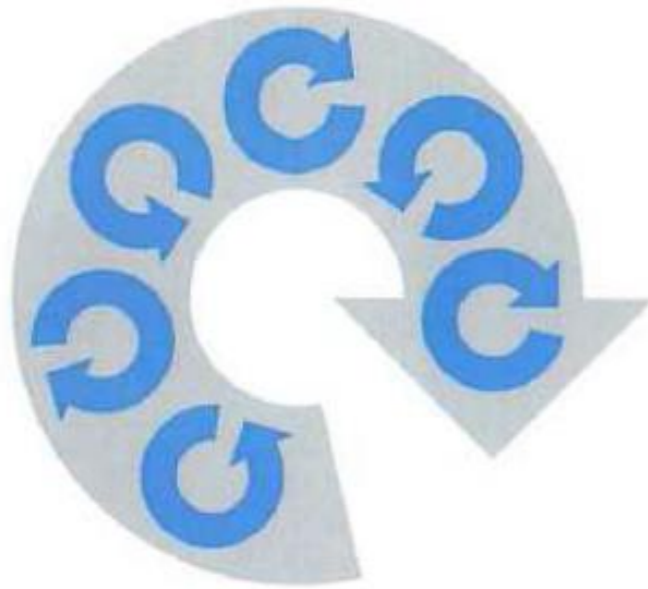

"Spiral" groove arrangement means

- High turbulent flow
- No fouling, no sedimentation
- High heat transfer
- Full counter flow

Block design

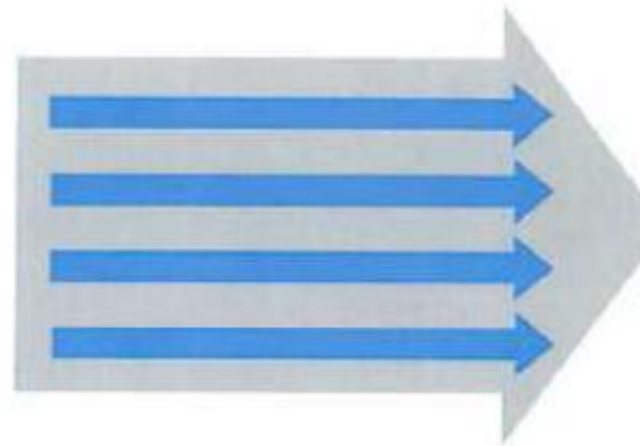

Linear flow arrangement means

- Laminar flow
- Tendency to fouling and sedimentation
- Lower heat transfer
- Only cross flow

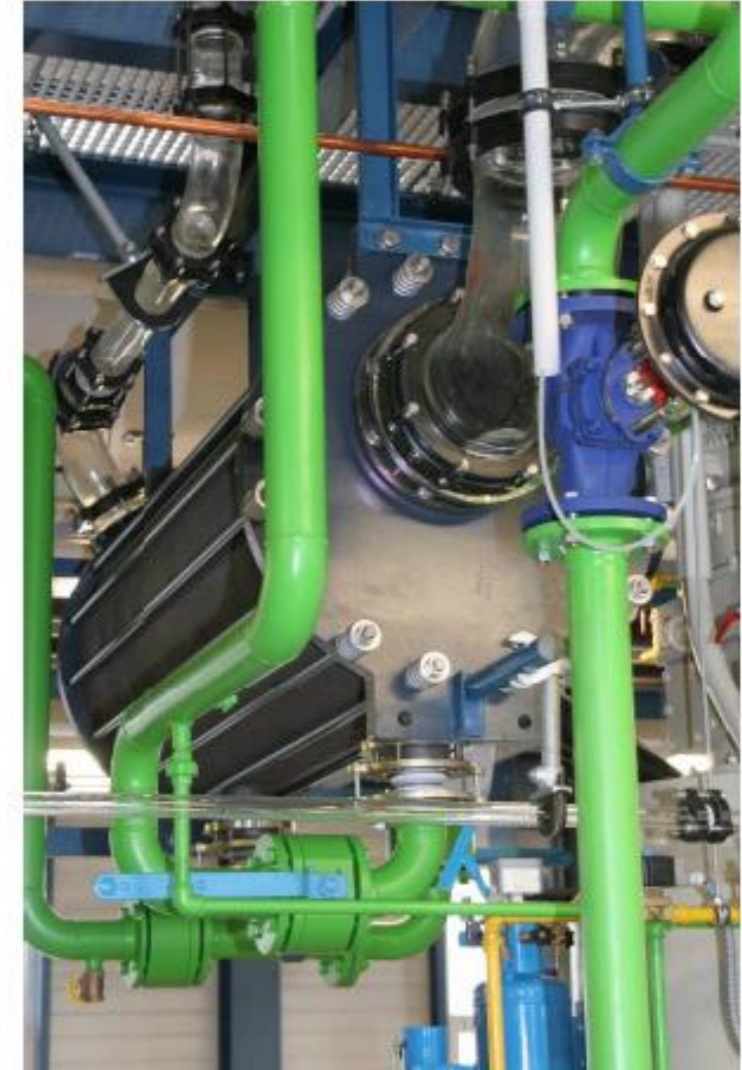

SYNTHETIC RESIN IMPREGNATED GRAPHITE HEAT EXCHANGERS ANNULAR GROOVE DESIGN BENEFITS

Overall heat transfer value (W/m² K)

	<i>Block</i>	<i>Annular-groove</i>	<i>Increase</i>
<i>Two aqueous liquids</i>	500-1.000	1.100-1.600	+ 60-120%
<i>Water and organic solvents</i>	400-700	600-1.200	+ 50-70%
<i>Water and acid</i>	400-700	600-1.400	+ 50-100%
<i>Water and condensing steam</i>	600-1.100	1.300-1.800	+ 60-130%
<i>Water and condensing solvents</i>	400-700	700-1.300	+ 75-90%
<i>Heating steam and evaporating water</i>	800-1.100	1.400-1.800	+ 65-75%
<i>Heating steam and organic solvent</i>	600-900	800-1.400	+ 35-55%
<i>Heating steam and acid</i>	500-900	700-1.400	+ 40-55%



Average heat transfer value indicating the thermal performance annular-groove heat exchanger vs. block heat exchanger

SYNTHETIC RESIN IMPREGNATED GRAPHITE HEAT EXCHANGERS ANNULAR GROOVE DESIGN BENEFITS

Block and Annular-groove h.e. sizes (at comparable heat load)

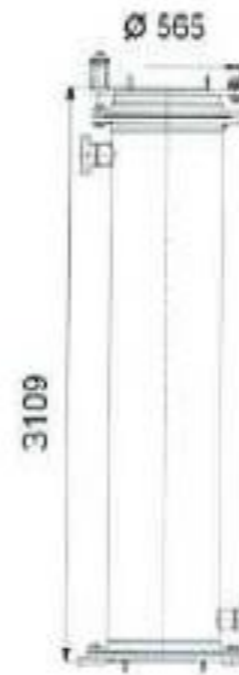

Block
18,2 m² transfer area

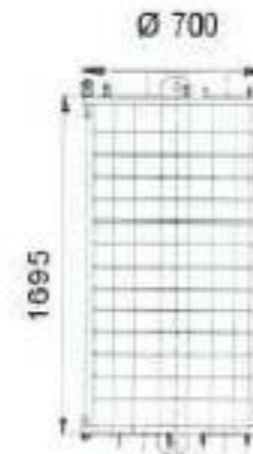

Annular-groove
13,8 m² transfer area

*Block (Lecarbhone Lorraine) vs. Annular-groove GAB
Acid heating with steam
(Jordan Phosphate Mines)*

SYNTHETIC RESIN IMPREGNATED GRAPHITE HEAT EXCHANGERS

ANNULAR GROOVE BENEFITS

Annular-groove design

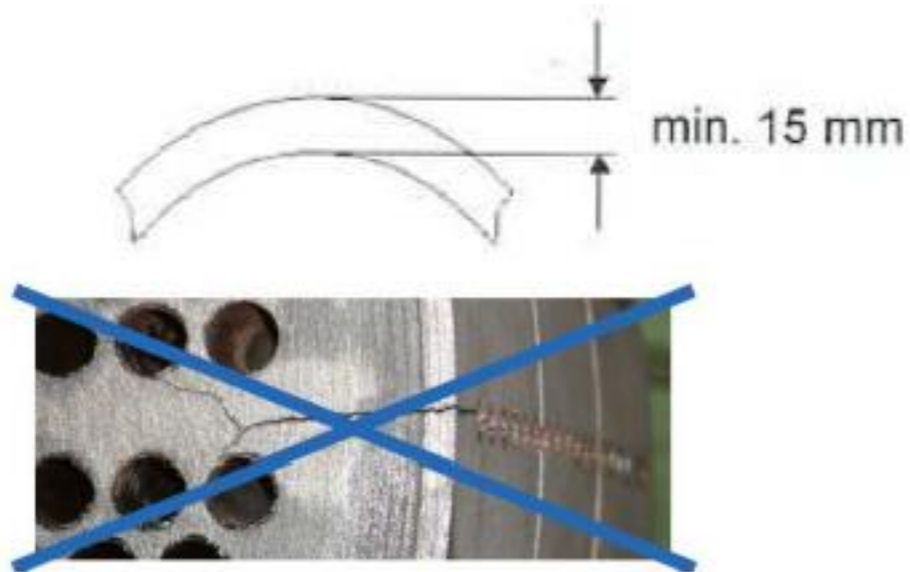

High wall thickness means

- No leakage
- No cracks
- Stress is very unlikely to exceed the maximum allowed

Block design

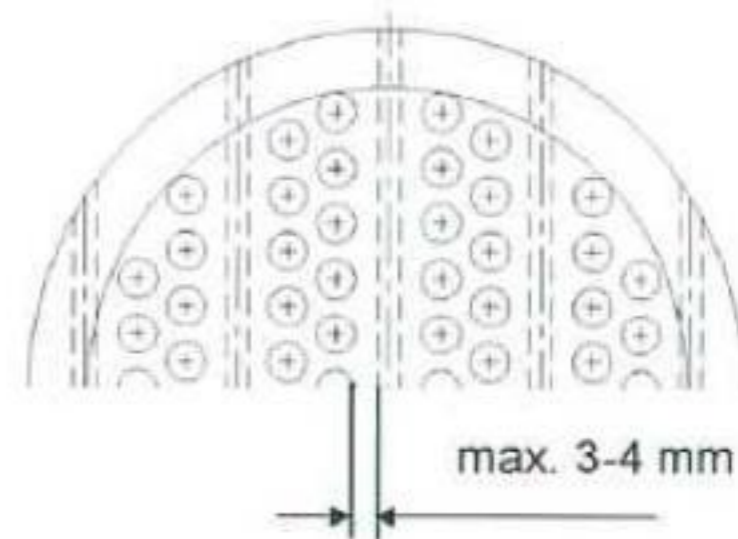

Small wall thickness (3-4 times smaller than Annular-groove)

- Risk of leakage
- Risk of cracks
- Stress exceeds the maximum allowed easily

SYNTHETIC RESIN IMPREGNATED GRAPHITE HEAT EXCHANGERS ANNULAR GROOVE CONDENSER

Reactor			Required transfer area (m ²) at condensating temperature of...							
Type	Area m ²	Heat load kW	> 100 °C Toluol, Water		> 75 °C Benzene, Ethanol		> 65 °C Methanol		> 55 °C Acetone	
AE 63	0.56	10	0.2	1)	0.3	1)	0.37	1)	0.6	1)
AE 100	0.88	16	0.27	1)	0.45	1)	0.59	1)	1.0	1)
AE 160	1.25	23	0.38	1)	0.65	1)	0.85	1)	1.4	2)
AE 250	1.7	31	0.52	1)	0.88	1)	1.14	1)	1.9	2)
AE 400	2.5	45	0.75	1)	1.3	2)	1.7	2)	2.1	2)
AE 630	3.1	56	0.93	1)	1.6	2)	2.1	2)	2.6	3)
AE 1000	4.6	83	1.4	2)	2.4	2)	3.1	3)	3.8	3)
BE 1600	7.3	131	2.2	2)	3.7	3)	4.8	4)	6.1	4)
BE 2500	9.7	175	2.9	3)	5.0	4)	6.4	4)	8.1	5)
BE 4000	13.4	241	4.0	3)	6.8	4)	8.9	5)	11.2	5)
BE 6300	18.1	326	5.4	4)	9.3	5)	12.0	5)	15.1	6)
BE 8000	18.0	324	5.4	4)	9.2	5)	11.9	5)	15.0	6)
BE 10000	20.7	373	6.2	4)	10.6	5)	13.7	6)	17.3	7)
BE 12500	25.2	454	7.6	5)	12.9	6)	16.7	6)	21.0	7)
BE 16000	29.5	531	8.9	5)	15.1	6)	19.5	7)	24.6	8)
BE 20000	34.0	619	10.2	5)	17.4	7)	22.5	8)	28.3	8)

(see also Work Standard 1562)

Standardised Condensators
(recommendation)

- 1) GN1-06-9 (1,08 m²)
- 2) NB5-05 (2,5 m²)
- 3) NB5-08 (4,0 m²)
- 4) NB6-08 (6,4 m²)
- 5) NB7-10 (11,5 m²)
- 6) NB7-14 (16,1 m²)
- 7) NB7-18 (20,7 m²)
- 8) NB7-26 (29,9 m²)

see also Product Info
RN-11 resp. RN-9 (GMP),
RN-18 resp. RN-10 (GMP)
GN-1

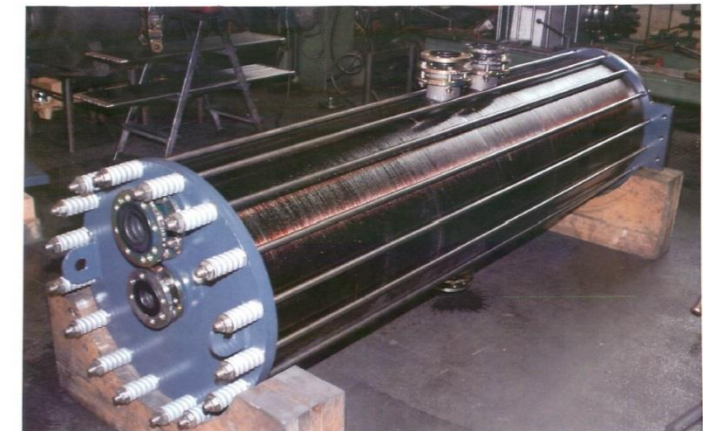

GAB Neumann GmbH | Alemannenstrasse 29 | 79689 Maulburg
T +49 (7622) 6751-0 | F +49 (7622) 6751-20 | info@gab-neumann.de

GAB
neumann
Graphite Heat Exchangers
and Components

SYNTHETIC RESIN IMPREGNATED GRAPHITE HEAT EXCHANGERS ANNULAR GROOVE GMP DESIGN TYPE

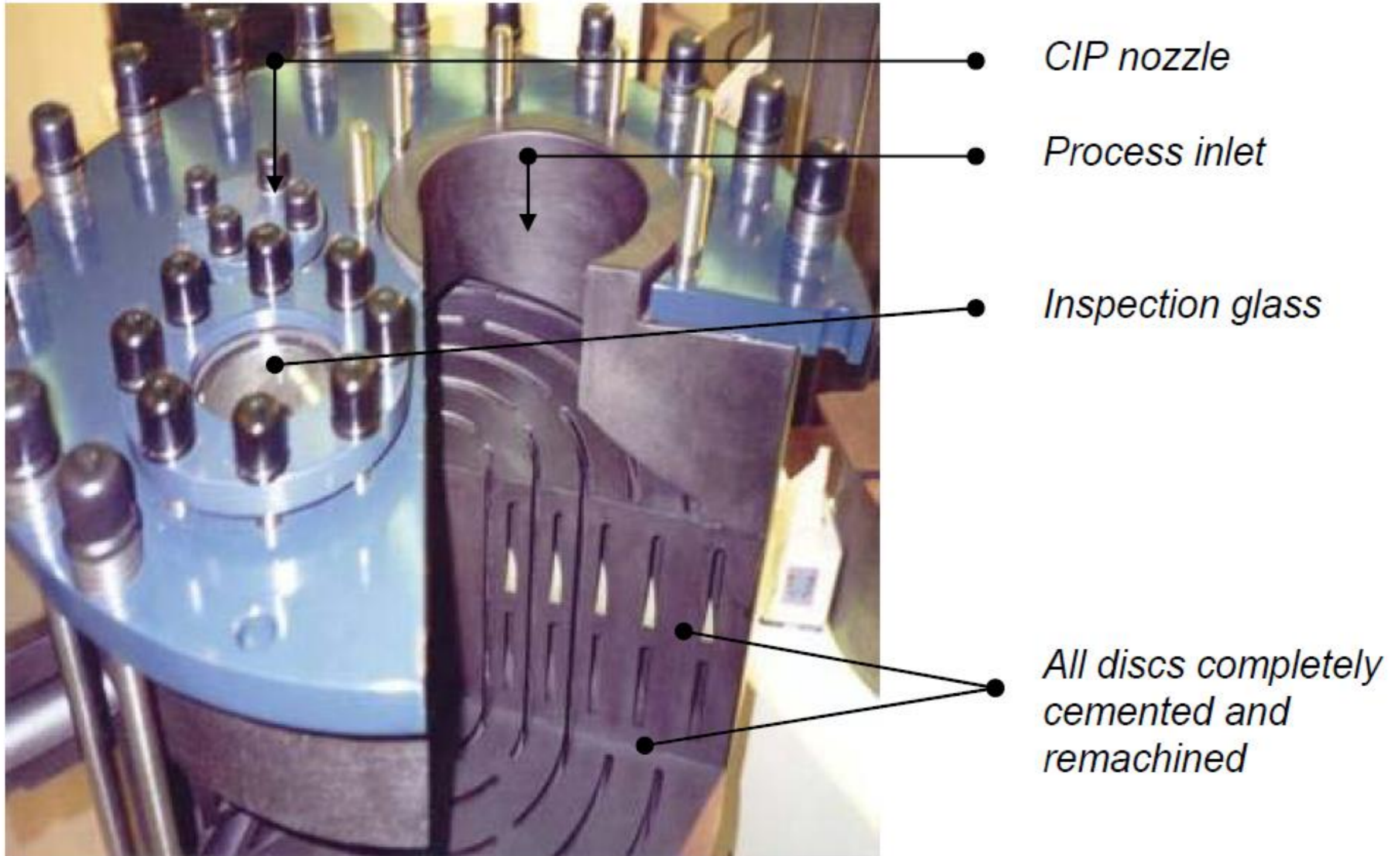

ANNULAR GROOVE PROCESS EQUIPMENT

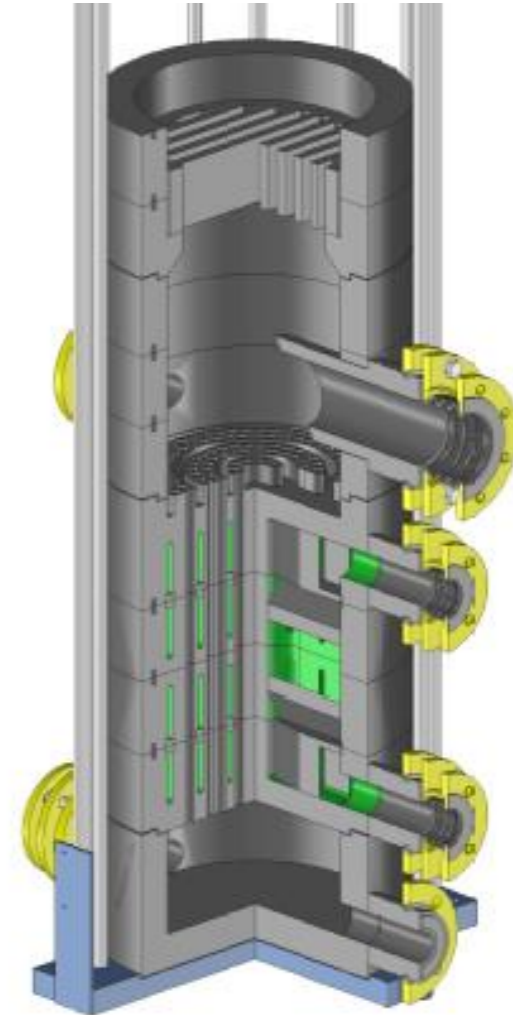
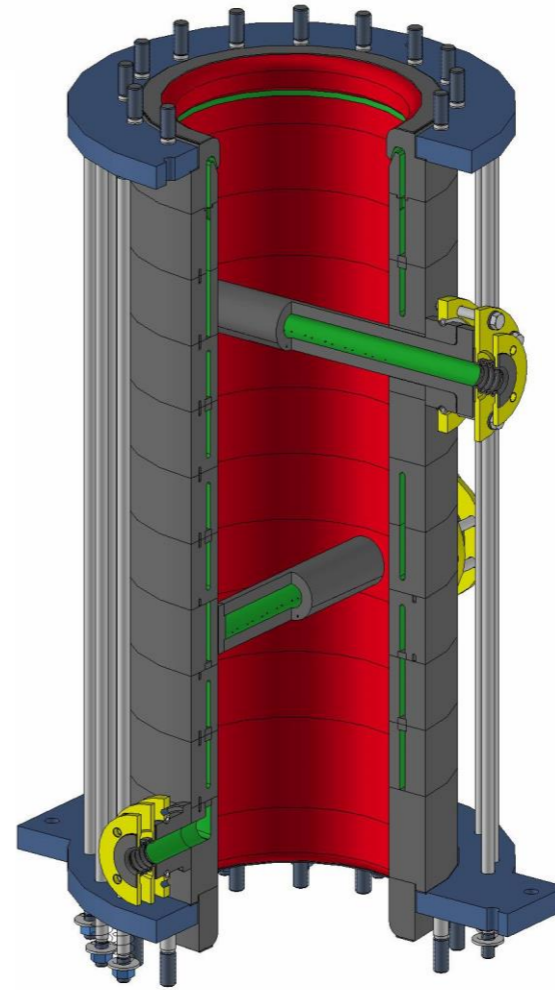
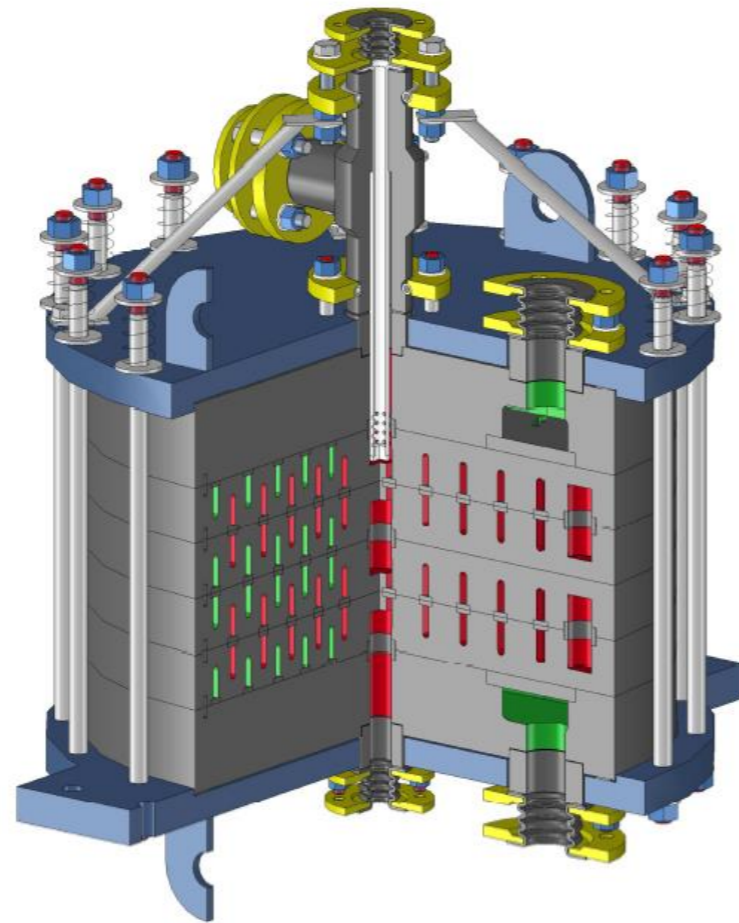
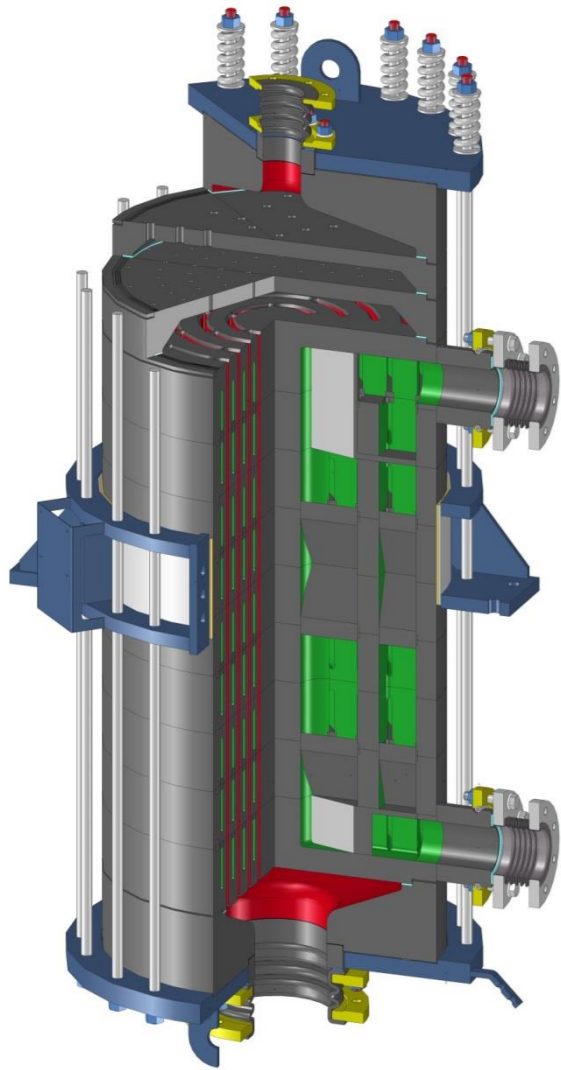

SYNTHETIC RESIN IMPREGNATED GRAPHITE COLUMN INTERNALS



SILICON CARBIDE CORROSION RESISTANCE

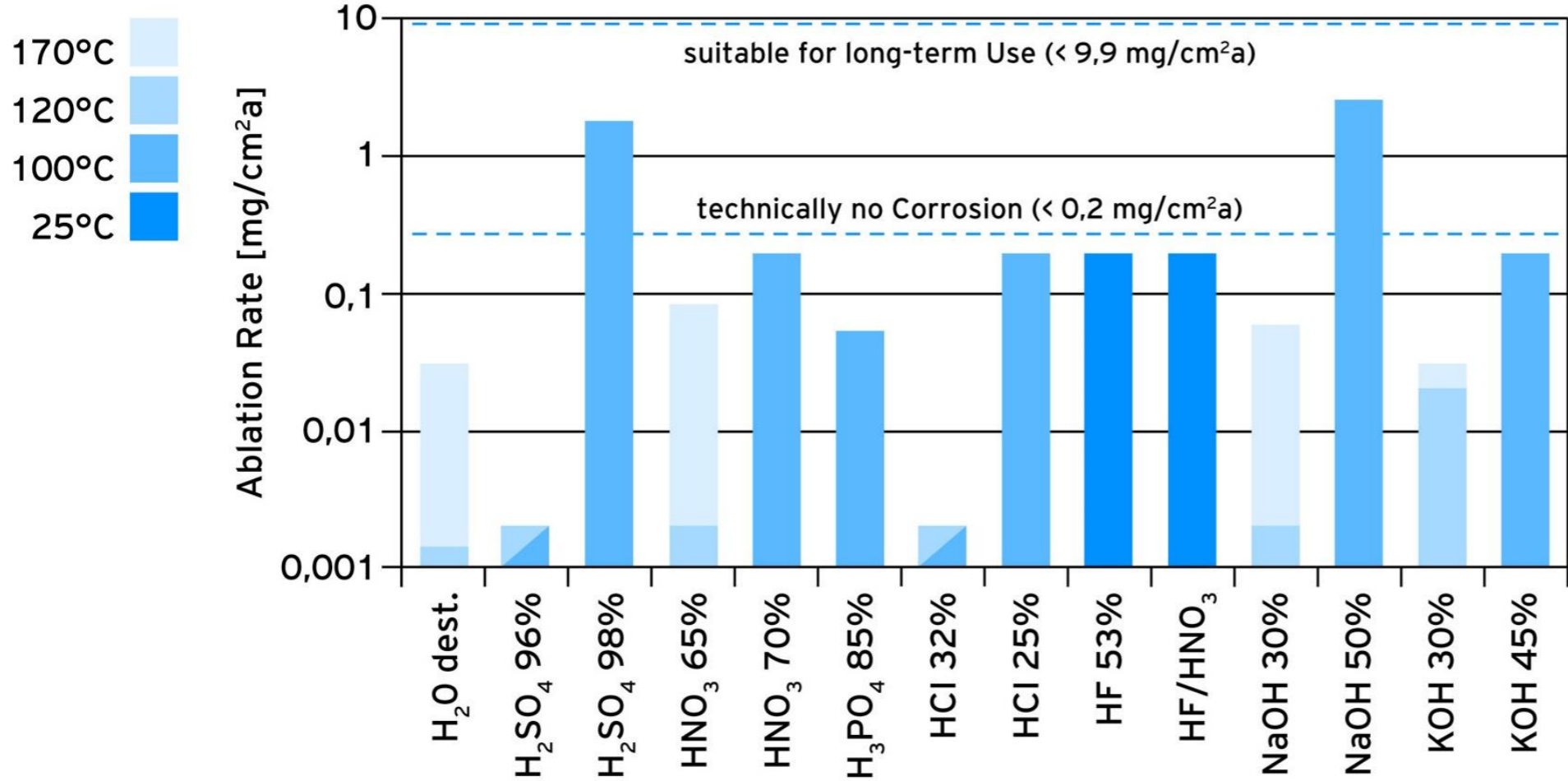

SILICON CARBIDE PROPERTIES

Density (20°C)	kg/m ³	3,1
Flexural strength (20°C)	N/mm ²	460
Compressive strength (20°C)	N/mm ²	2900
Elasticity modulus (20°C)	Gpa	410
Weibull-module		>12
Thermal conductivity	W/mK	130
Free porosity	%	0



CORRESIC® HEAT EXCHANGERS DESIGN

- Extend product range by SiC products (intended annular-groove, shell & tube (and block))

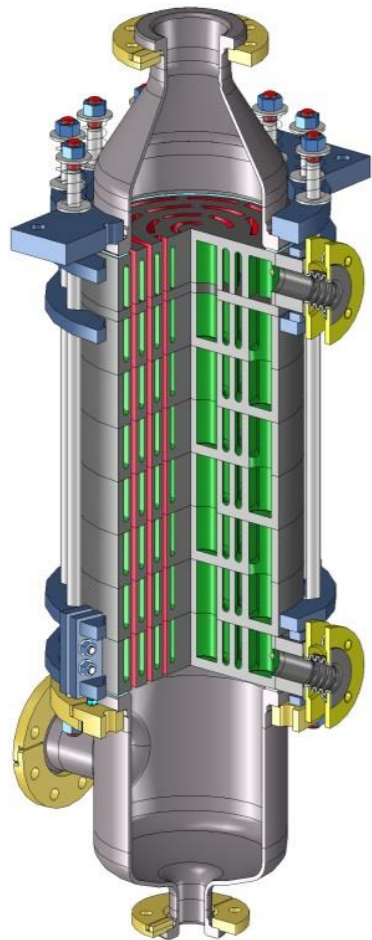

CORRESIC® annular-groove heat exchanger

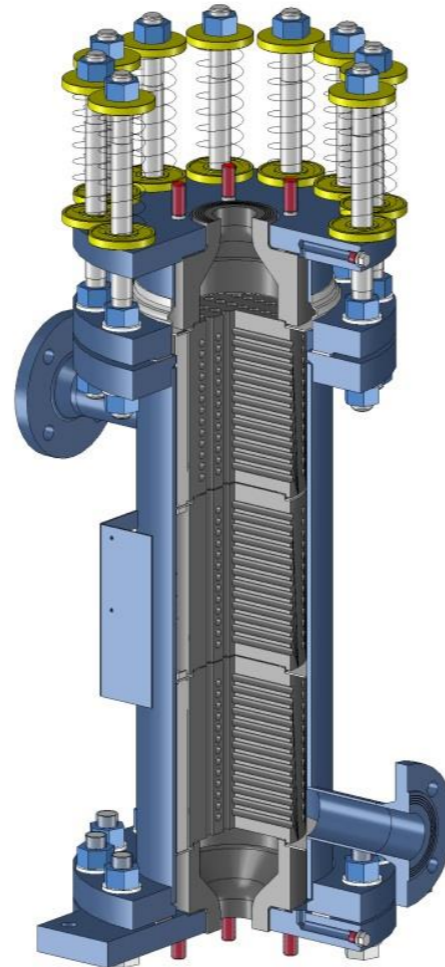

CORRESIC® Block heat exchanger

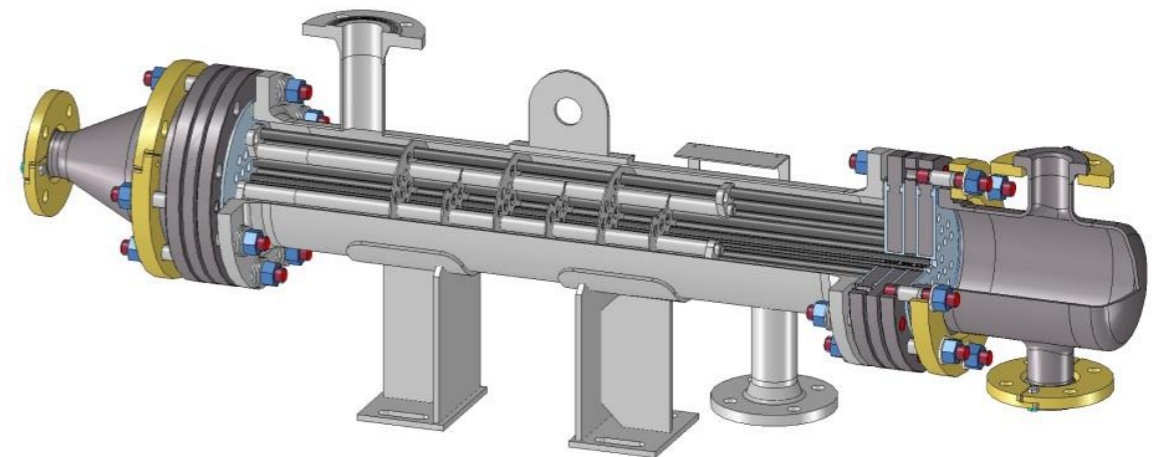

CORRESIC® Shell & tube heat exchanger

CORRESIC® Compact Sealing System

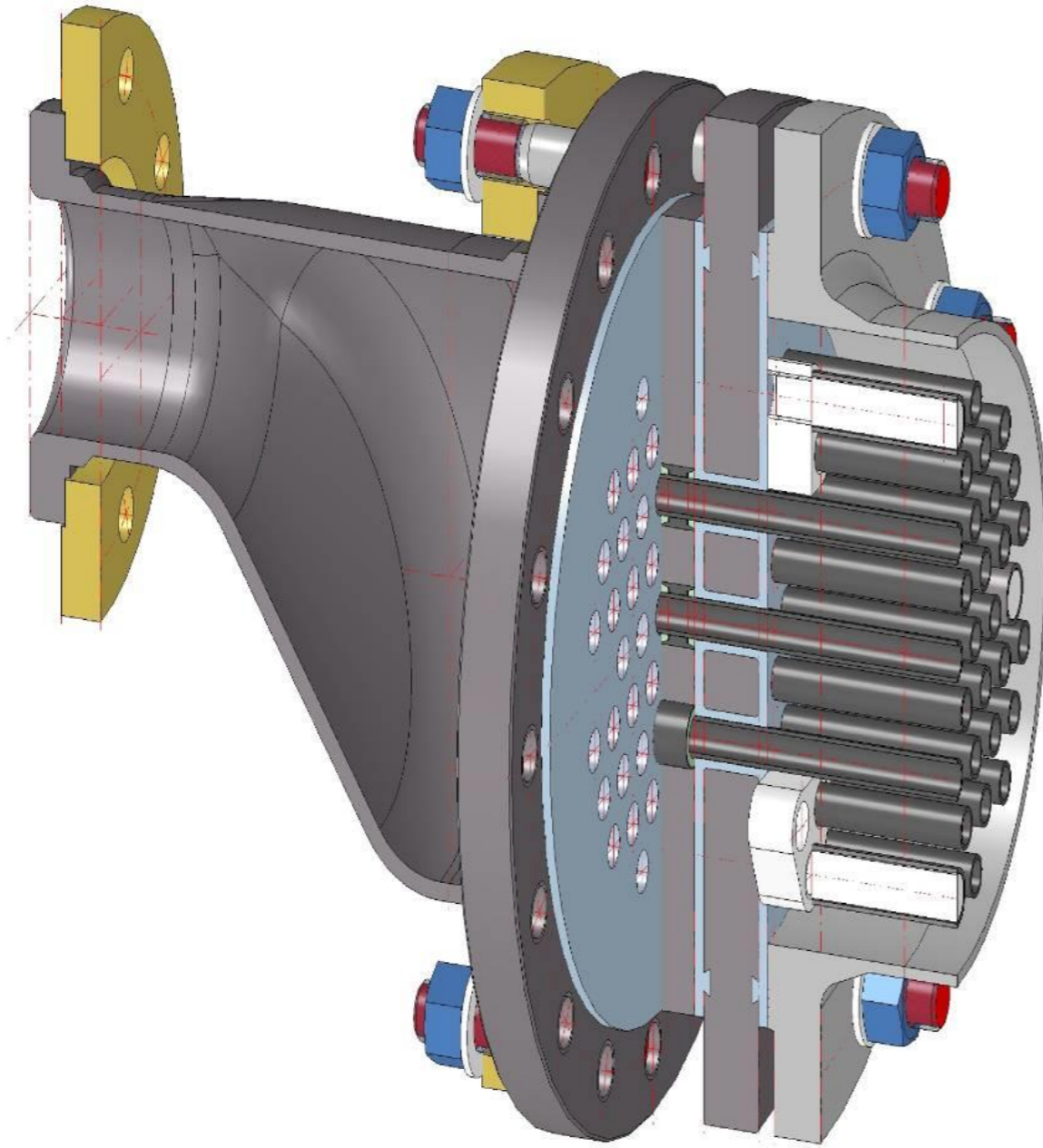

- Compact sealing system with double sealing as standard > minimised risk of cross contamination
- Sealing face in thermally resistant sleeve > no creeping at high temperatures
- No sinkings for sealing in tube sheet > more compact bundling of tubes means up to 35% more transfer area > strengthened steel core for better stability and therefore...
- ...fixing of the tube sheets only by outer pitch circle > no corrosion risk by coated screws compressing the tube sheets

CORRESIC®-SB Compact Sealing System

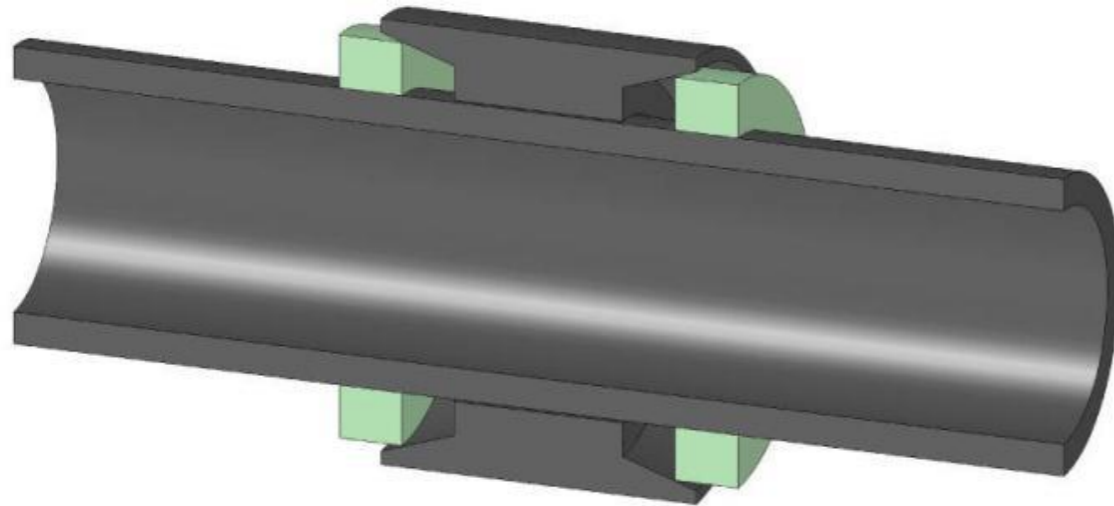

Sealing system before compression

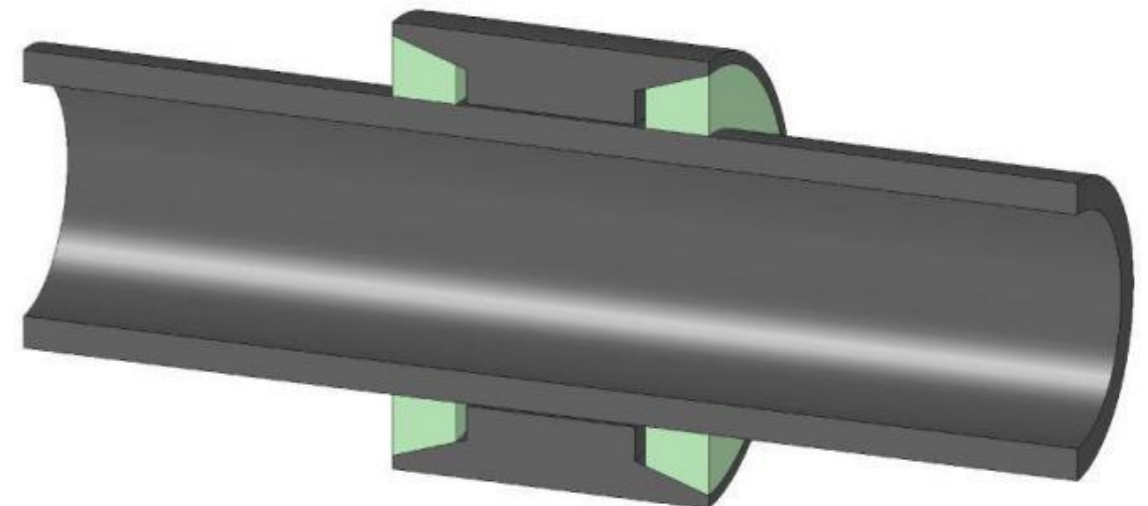

Sealing system after compression by the tube sheets

- Thermally resistant sleeve incorporates the sealing faces and enables perfect sealing
- Use of gaskets with rectangular profile for highest sealing forces
- Easy replacement of tubes at discharged gaskets / compression plates
- Temperature options: low temp. range + standard temp. range

CORRESIC[®]-SB Leakage detection system

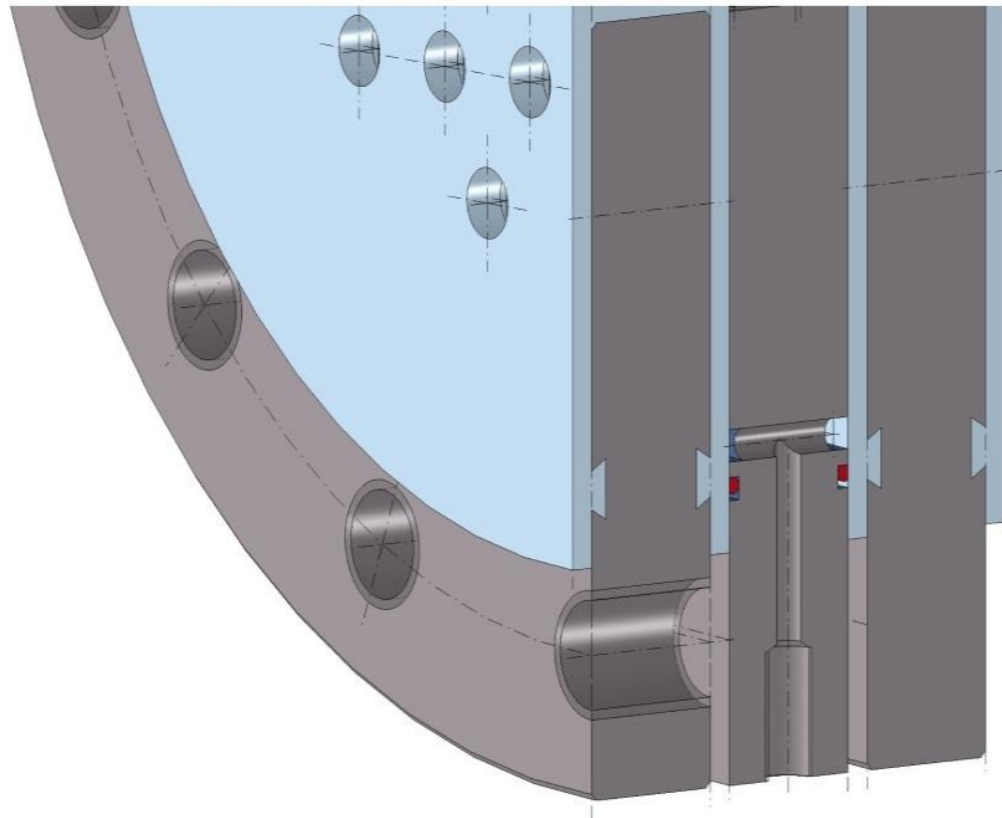

Tube sheet (assembled) with leakage detection system

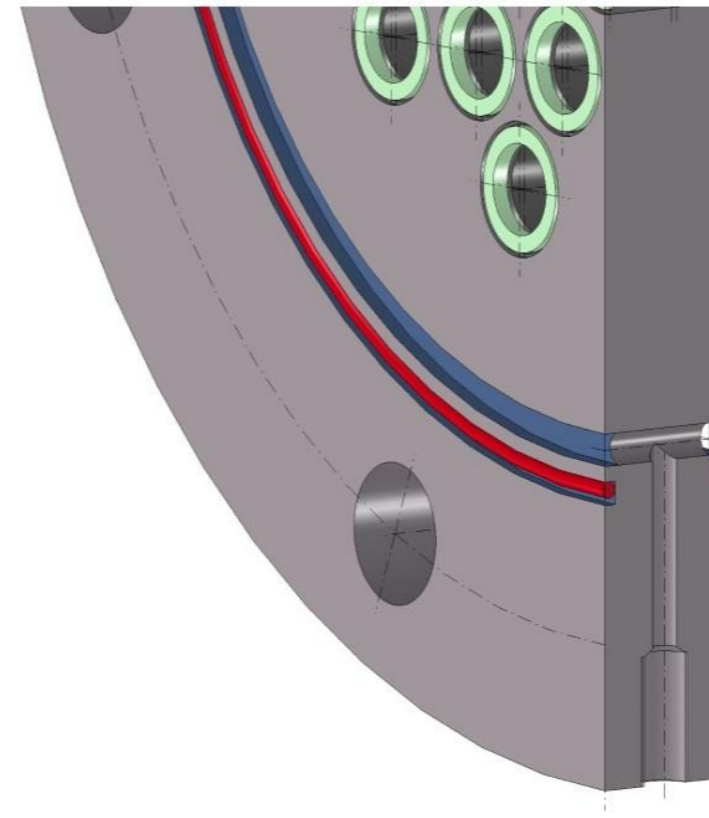

Spacer disc with draining channels and gasket

- The leakage detection system (optional feature) allows to detect failing gasket in double sealing

CORRESIC®-SB Design

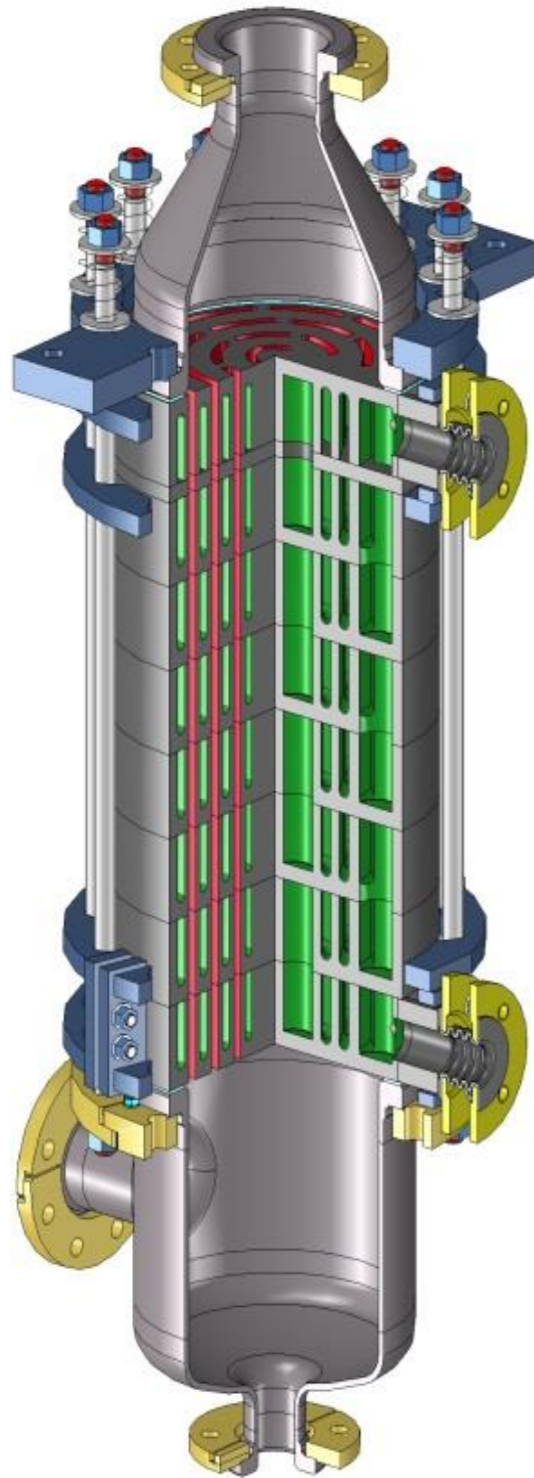

- Monolithic discs in pressureless sintered SSIC material for best corrosion resistance
- Corrosion and temperature resistant TASIC® fusing based on fluoropolymers
- Dead corner free design enabled by TASIC® fusing process
- Helical springs for sustainable sealing forces throughout the total range of operation
- Main data
 - Heat transfer area up to 10 m²
 - Disc diameter 320 and 430 mm
 - -1 bar to +6 (+10) bar
 - -10 (-60) °C to +200 (+220) °C

CORRESIC®-SE Design

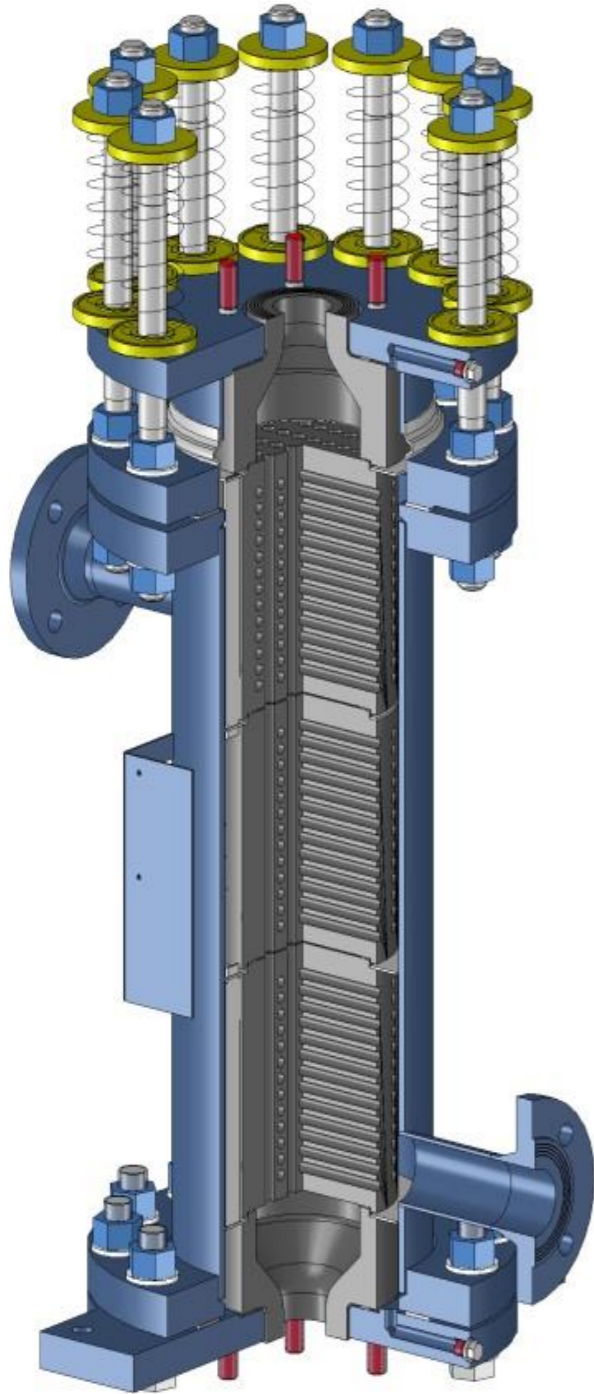

- Monolithic blocks and headers in pressureless sintered SSiC material for best corrosion resistance
- Modular design with PTFE gaskets and PTFE or stainless steel baffles
- Steel shell with axial compensator for thermal dilatation
- Helical springs for sustainable sealing forces throughout the total range of operation
- Main data
 - Heat transfer area 0,3 m² to 20 m²
 - Block diameter 160, 260 and 350 mm
 - -1 bar to +10 (+16) bar
 - -10 (-60) °C to +200 (+220) °C

CORRESIC®-SE Applications



- Liquid/liquid heat exchange at all acids, brines and organic solvents, e.g. mixed acid, sulphuric acid, nitric acid
- Reboiler evaporation, especially steam heated
- Condensation processes with special need of robustness
- Pickling applications in steel and galvanic industries (heating, cooling, acid regeneration)
- Acid concentration processes