

Series 10 Mixers

TOP-ENTRY MIXERS



A World Leader In Industrial Mixing Since 1923. Lightnin has over 85 years of unrivaled experience in industrial mixing technology, process knowledge, and technological innovation. Lightnin enjoys a global reputation for durable, long-lasting mixers, agitators, aerators, and flocculators for fluid process systems. We offer a full spectrum of impeller designs for diverse applications. In addition, we offer a worldwide service network, mixer repair, gearbox repair, and replacement parts programs. Look to Lightnin for knowledge, technology and service excellence.

Based in Charlotte, North Carolina, SPX Corporation (NYSE: SPW) is a global Fortune 500 multi-industry manufacturing leader. The company's highly-specialized, engineered products and technologies serve customers in three primary strategic growth markets: infrastructure, process solutions, and diagnostic systems. Many of SPX's innovative solutions are playing a role in helping to meet rising global demand, particularly in emerging markets, for electricity, processed foods and beverages and vehicle services. The company's products include thermal heat transfer equipment for power plants; power transformers for utility companies; process equipment for the food & beverage industry; and diagnostic tools and equipment for the vehicle service industry. For more information, please visit www.spx.com.

Lightnin Series 10 Mixers - Durable, Versatile, Cost-effective

One look at this rugged design will tell you, Lightnin's field-proven Series 10 is no ordinary mixer. In thousands of installations and hundreds of applications worldwide, Series 10 mixers deliver a superior combination of value and performance. **Comes with Lightnin's process guarantee.**

UNMATCHED DURABILITY

- **Long gear and bearing life:** The largest tapered roller bearings in a mixer of this class help produce an L10 life of 100,000 hours and greater. Designed specifically for mixer service, Series 10 speed reducers are capable of handling large variations in mixer loads, adapting to different process conditions and accommodating long overhung shafts. "Off-the-shelf" speed reducers not designed for mixer service can't make this claim.

In addition, high-quality carburized and ground gearing features a minimum AGMA Service Factor of 1.5 for long life and added protection against shock loading.

- **Unique output shaft connection - the largest of any competitive unit - reduces shaft deflection to extend seal life:** Greater mechanical stiffness reduces deflection at the seal (less than 0.26mm / 0.010 inches) compared with seal-on-a-sleeve or cartridge designs. As a result, you'll be able to specify longer overhung shafts and replace seals less frequently. When servicing is called for, there is no output shaft seal on any mixer in the world that's quicker (30 minutes or less) or easier to replace.

EXCELLENT VERSATILITY

- **Wide range of output speeds:** Select the combination of output speed and torque that meets your mixing requirements. Output speeds from 9rpm to 125rpm; 0.75kW to 22kW (1hp to 30hp).
- **Choice of motors:** Select the motor that's consistent with your specific plant standards. A wide variety of motor options is available, including explosion-proof and multiple-speed units.
- **Longer shaft lengths accommodate a wider range of tank configurations:** Carbon steel or 316 stainless steel shafts are standard. Shafts in excess of 9 meters (30 feet) in length let you specify Series 10 mixers for large tanks without the need for steady bearings. High alloy and composite shafts are also available.
- **Choice of mechanical seals:** Closed-tank mixers can be equipped with dry-running single mechanical seals or lubricated double mechanical seals for hazardous materials and higher-pressure applications.

- **Optional seal pedestal design eliminates temperature constraints:** Series 10 mixers can be mounted on a pedestal to permit operation up to vessel temperatures of 204° C (400° F).
- **Dry-well construction and no submerged seals prevent oil leakage:** An integral reducer housing with dry well construction prevents oil loss, as well as the risk of product contamination. The reducers simply can't leak; even when the mixer is mounted on angle risers (shown below). In addition, the absence of submerged oil seals or split lines below the oil level prevent leakage over the tank or into the product.
- **International Legislation:** Lightnin Series 10 can be built and certified to meet the requirements of CE, ATEX, PED, GOST, RTN (including technical passports), Norsok, VIK and DNV DRILL(N), as well as other certifications that might be required.

THEORY OF OPERATION:

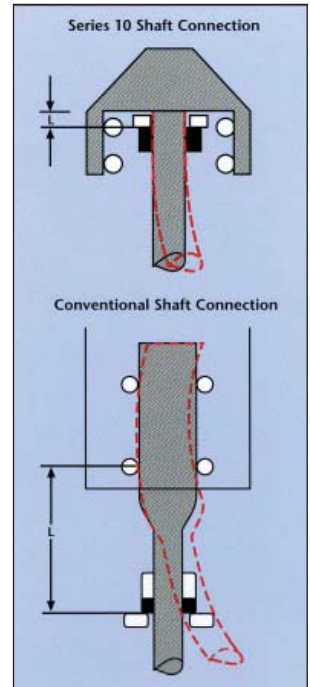

Distance between seal face and rigid support (L) is shorter in Series 10 design compared to conventional design, minimizing shaft deflection at seal face.

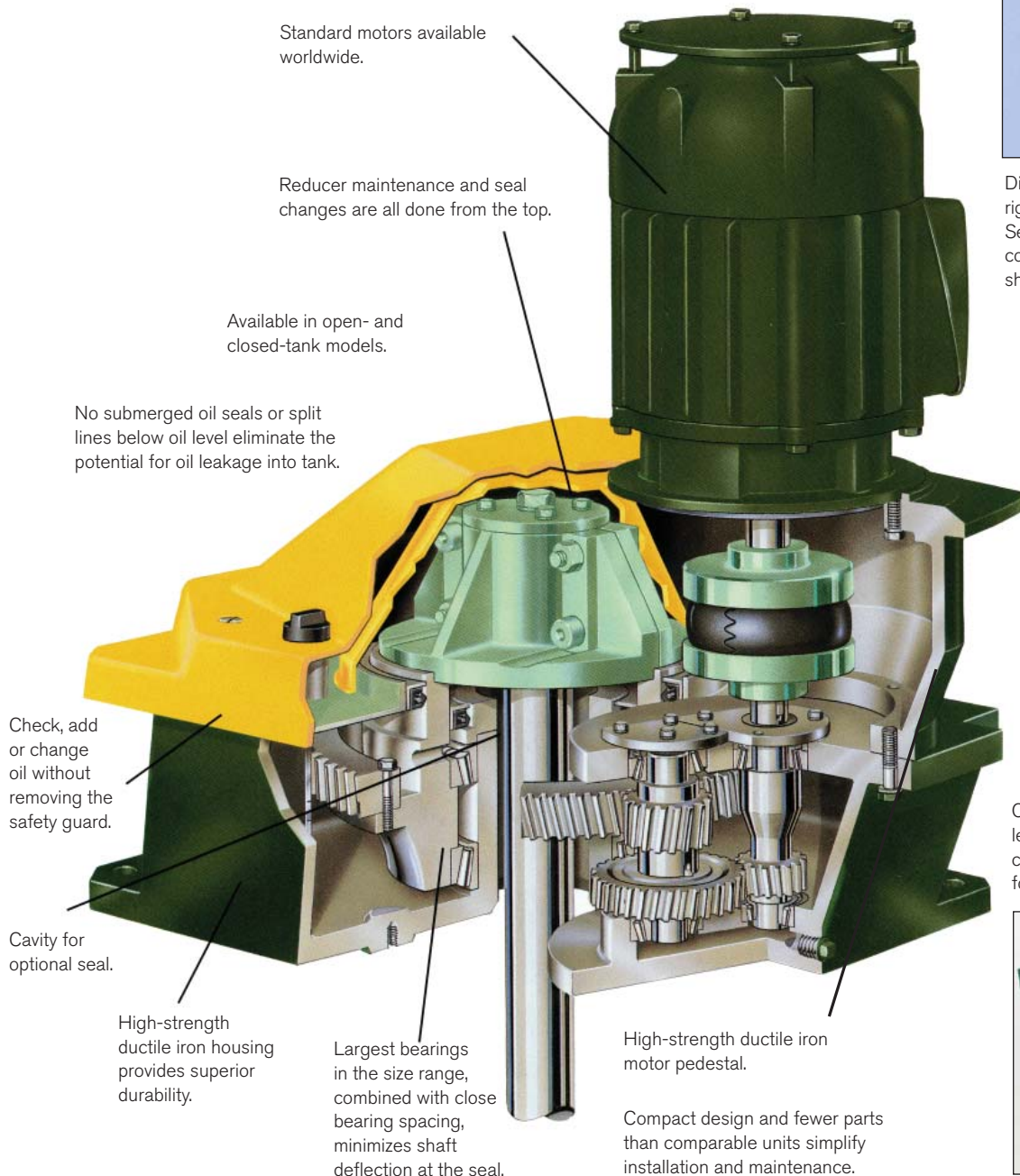

Optional angle riser brackets let you save up to 15% on tank costs by eliminating the need for baffles.



SPX INDUSTRIAL PROCESSES

LOWER OWNERSHIP COSTS

- **Fewer moving parts simplifies maintenance:** Series 10 mixers let you reduce spare parts inventory, frequency of repair and servicing costs.
- **Perform routine maintenance quickly:** Check, add or change oil without removing the high-strength safety guard. Synthetic oil needs to be changed only once a year. Oil-lubricated gears and bearings do not require grease servicing.
- **Easy, fast seal replacement:** Seals are replaced from the top of the mixer without disturbing the shaft. Fast replacement means more uptime and lower maintenance costs.
- **High-efficiency helical gearing provides more usable power:** Efficient in-line helical gearing and parallel shafts minimize horsepower loss through the drivetrain. As a result, virtually all the power you pay for is transferred into the mixing vessel.

30 - MINUTE SEAL REPLACEMENT

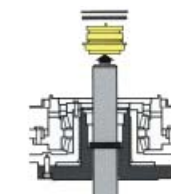
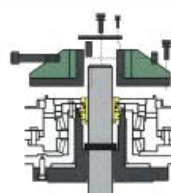
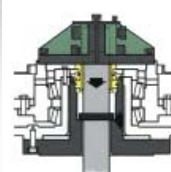

Seal changes are performed in less than 30 minutes. Simply loosen hardware and lower the shaft support collar onto the hub shoulder (1). Once the split coupling has been removed (2), lift off the seal assembly and replace with a new or rebuilt unit (3).

Global locations

USA

SPX GLOBAL HEADQUARTERS

13515 Ballantyne Corporate Place
Charlotte, NC 28277
United States of America
+1 704 752 4400

APAC

SPX ASIA PACIFIC

2F, Treasury Building
1568 Hua Shan Road
Shanghai 20000523
Peoples Republic of China
+86 21 2208 5888

EMEA

SPX EUROPE

Ocean House
Towers Business Park
Wilmslow Road
Manchester, M20 2LY England
+44 (0) 161 2491170

SPX FLOW TECHNOLOGY

135 Mt. Read Blvd.
Rochester, NY 14611
P: (888) 649-2378 (MIX-BEST), US and Canada) or +1 (585) 436-5550
F: (585) 436-5589
E: lightnin@spx.com ▪ www.lightninmixers.com

For other Sales locations click
<http://www.spx.com/en/lightnin/where-to-buy/>
or use your SmartPhone and the QR Code



SPX reserves the right to incorporate our latest design and material changes without notice or obligation.

Design features, materials of construction and dimensional data, as described in this bulletin, are provided for your information only and should not be relied upon unless confirmed in writing. Please contact your local sales representative for product availability in your region. For more information visit www.spx.com.

The green ">" is a trademark of SPX Corporation, Inc.