

Series 80 Mixers

HEAVY-DUTY MIXERS

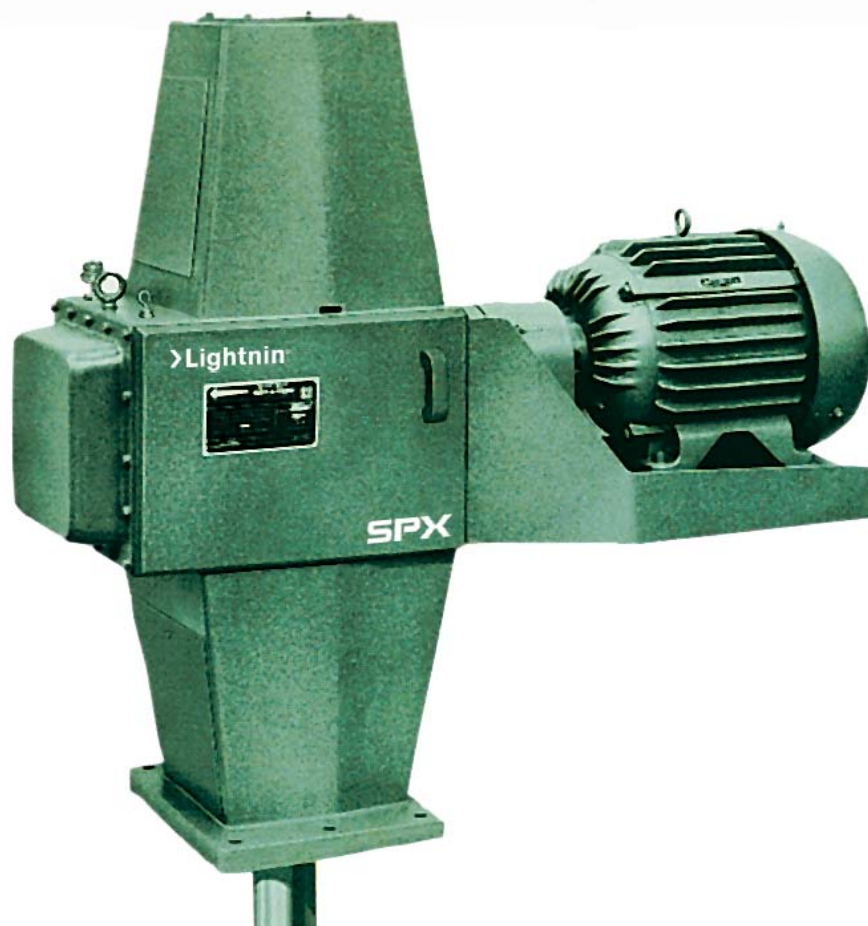

A World Leader In Industrial Mixing Since 1923. Lightnin has over 85 years of unrivaled experience in industrial mixing technology, process knowledge, and technological innovation. Lightnin enjoys a global reputation for durable, long-lasting mixers, agitators, aerators, and flocculators for fluid process systems. We offer a full spectrum of impeller designs for diverse applications. In addition, we offer a worldwide service network, mixer repair, gearbox repair, and replacement parts programs. Look to Lightnin for knowledge, technology and service excellence.

Based in Charlotte, North Carolina, SPX Corporation (NYSE: SPW) is a global Fortune 500 multi-industry manufacturing leader. The company's highly-specialized, engineered products and technologies serve customers in three primary strategic growth markets: infrastructure, process solutions, and diagnostic systems. Many of SPX's innovative solutions are playing a role in helping to meet rising global demand, particularly in emerging markets, for electricity, processed foods and beverages and vehicle services. The company's products include thermal heat transfer equipment for power plants; power transformers for utility companies; process equipment for the food & beverage industry; and diagnostic tools and equipment for the vehicle service industry. For more information, please visit www.spx.com.

The Lightnin Shock Absorber - Series 80

Thousands of Lightnin Mixers with hollow quill drives have been placed in service since we first created the design in the late 1960's to protect the gear train from severe flexures of the shaft. The exclusive hollow quill became part of the Series 80 mixers at that time. Since, then, the design has written a singular record for isolating shaft flexures and assuring longer life in some of the toughest applications imaginable. Series 80 mixers are especially recommended for processes with high fluid forces on the impellers, and long impeller shaft applications. Gearing is the same as used in our Series 70 and 500 mixers. Altogether, there are tens of thousands of these drives at work every day around the world. It's our standard and the standard of the industry.

PRODUCT BENEFITS AND FEATURES

- **1 - 200 HP (1 kW – 150 kW):** Lightnin Series 80 mixers cover the range from 1-200 hp (1 kW – 150 kW). They are available in both double and triple reduction gearing, and come in a full range of standard AGMA speeds from 280 down to 16.5 rpm.
- **Full Spectrum of Impellers:** Series 80 mixers offer a full choice of impellers in order to optimize your process results. Included are the high-flow A310/A510, as well as other high performance and more traditional impellers, so we can match shear and flow to your process requirements exactly.
- **Guaranteed Performance:** Together, we decide what mixing should do to optimize your process. Then, we recommend the impeller, mixer speed, shaft length and other specifications. And we guarantee performance results.
- **Tested 100%:** We employ a non-load test run on every Series 80 before it is shipped.

Open Tank Models- Series 80 models for open tanks require minimum headroom to simplify installation.



Typical product applications

THEORY OF OPERATION:

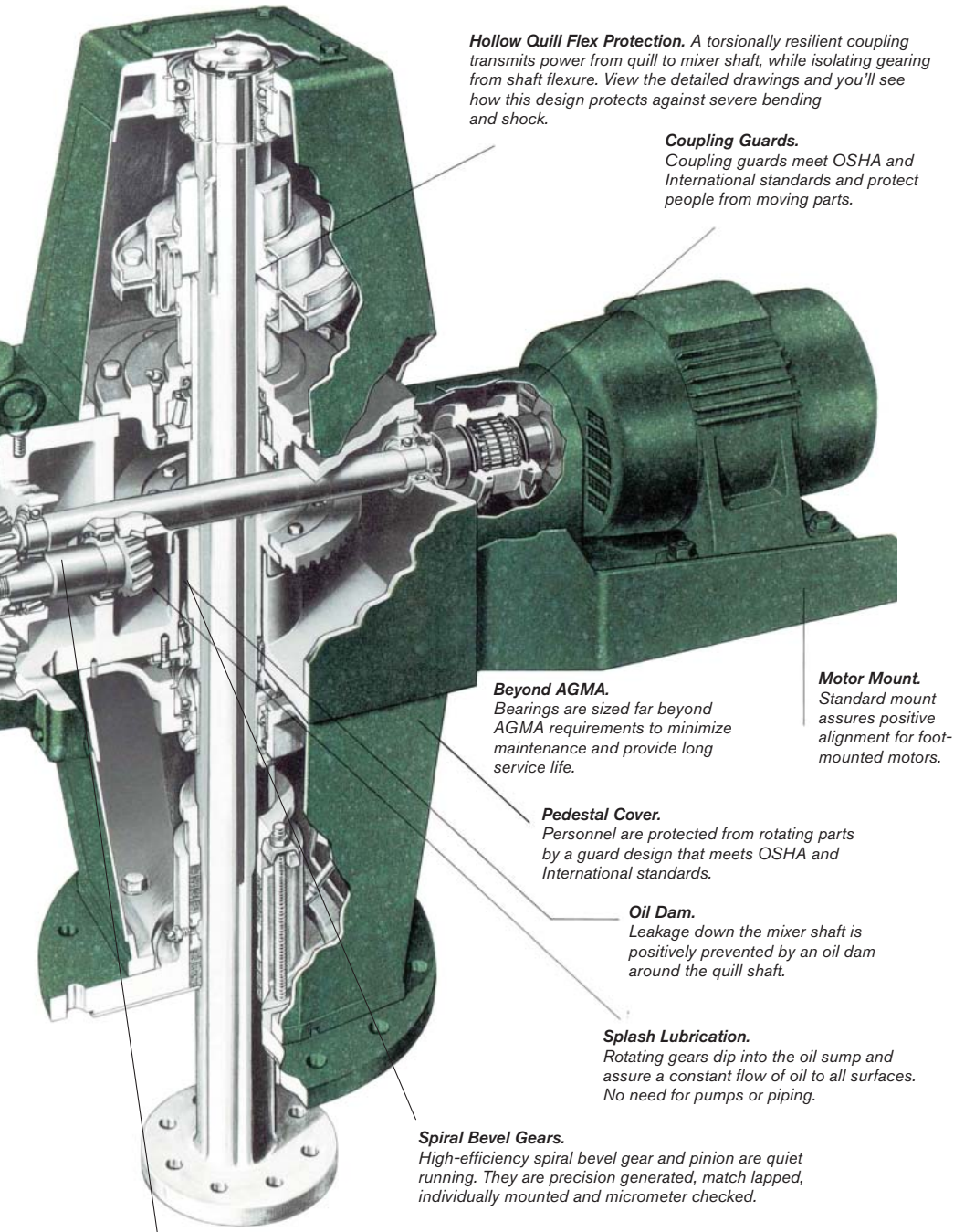

Hollow Quill Flex Protection. A torsionally resilient coupling transmits power from quill to mixer shaft, while isolating gearing from shaft flexure. View the detailed drawings and you'll see how this design protects against severe bending and shock.

Coupling Guards. Coupling guards meet OSHA and International standards and protect people from moving parts.

Beyond AGMA. Bearings are sized far beyond AGMA requirements to minimize maintenance and provide long service life.

Pedestal Cover. Personnel are protected from rotating parts by a guard design that meets OSHA and International standards.

Oil Dam. Leakage down the mixer shaft is positively prevented by an oil dam around the quill shaft.

Splash Lubrication. Rotating gears dip into the oil sump and assure a constant flow of oil to all surfaces. No need for pumps or piping.

Spiral Bevel Gears. High-efficiency spiral bevel gear and pinion are quiet running. They are precision generated, match lapped, individually mounted and micrometer checked.

Change Gears. Easily replaceable, helical gears are standard, so speed changes are easily made to meet new process requirements. No special tools. No need to dismantle the mixer or remove it from the tank. Heavy wall pinions provide maximum protection against damage from accidental overloads.

Mechanical Seals. The replaceable cartridge design, a LIGHTNIN original, is standard on Series 80 units. Light-weight. Easy to replace. No other design offers so much convenience. Integral stuffing box and open tank designs also available.

Motor Mount. Standard mount assures positive alignment for foot-mounted motors.

Series 80 Mixers are a highly efficient heavy-duty mixer, suitable for use in a wide range of applications.

We guarantee, 100%, that every mixer will do the job we say it will do. We guarantee the desired mixing result, and we give you a full mechanical guarantee.

Aeration

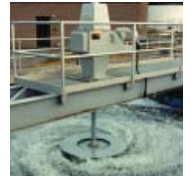

High Solids Concentration Mineral Processing



Tall Tanks



Gassed Processes



SPX[®] INDUSTRIAL PROCESSES

EXCLUSIVE HOLLOW QUILL CONSTRUCTION:

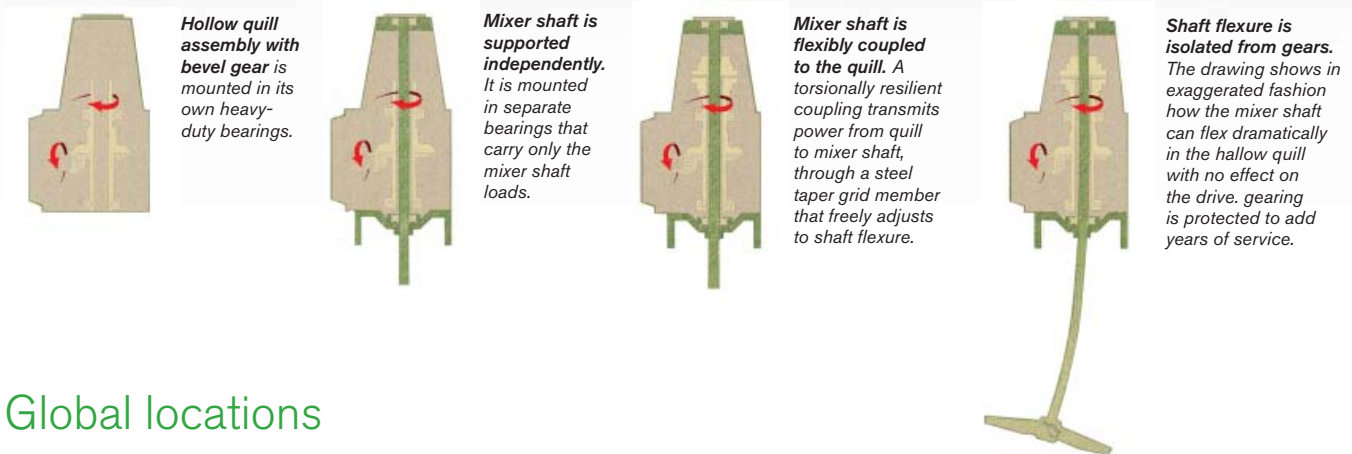

Hollow quill assembly with bevel gear is mounted in its own heavy-duty bearings.

Mixer shaft is supported independently. It is mounted in separate bearings that carry only the mixer shaft loads.

Mixer shaft is flexibly coupled to the quill. A torsionally resilient coupling transmits power from quill to mixer shaft, through a steel taper grid member that freely adjusts to shaft flexure.

Shaft flexure is isolated from gears. The drawing shows in exaggerated fashion how the mixer shaft can flex dramatically in the hollow quill with no effect on the drive, gearing is protected to add years of service.

Global locations

USA

SPX GLOBAL HEADQUARTERS

13515 Ballantyne Corporate Place
Charlotte, NC 28277
United States of America
+1 704 752 4400

APAC

SPX ASIA PACIFIC

2F, Treasury Building
1568 Hua Shan Road
Shanghai 20000523
Peoples Republic of China
+86 21 2208 5888

EMEA

SPX EUROPE

Ocean House
Towers Business Park
Wilmslow Road
Manchester, M20 2LY England
+44 (0) 161 2491170

SPX FLOW TECHNOLOGY

135 Mt. Read Blvd.
Rochester, NY 14611
P: (888) 649-2378 (MIX-BEST), US and Canada) or +1 (585) 436-5550
F: (585) 436-5589
E: lightning@spx.com • www.lightninmixers.com

SPX reserves the right to incorporate our latest design and material changes without notice or obligation.

Design features, materials of construction and dimensional data, as described in this bulletin, are provided for your information only and should not be relied upon unless confirmed in writing. Please contact your local sales representative for product availability in your region. For more information visit www.spx.com.

The green ">" is a trademark of SPX Corporation, Inc.